

Bill of Material for JRW Sheet Metal Brake

All dimensions in inches.

Plates are finished size.

¼ in. Mild Steel Plate

2 – 4 x 10 ½

½ in. Mild Steel Plate

2 – 1 ¼ x 10

1 – 4 ½ x 26 ¾

1 – 2 ¼ x 24 ¼

1 – 4 ½ x 24 1/8

2 – 2 ¾ x 5 ¾

1 – 2 x 23 1/8

2 – 2 ¾ x 5 11/32

2 – 2 x 10 ½

1 – 6 ½ x 24 ¾

2 – 4 ¼ x 7

2 – ¾ x 2

Round SS or Drill Rod

4 – ¾ DIA. 1 1/16

2 – ½ dia. x 5 ½

2 – ¾ dia. x 1 1/16

2 – 2 ¾ dia. x 1 ¼

1 – 5/8 dia. x 27 7/8

2 – 5/8 dia. x 1 1/8

Bronze Bearings

4 - ¾ ID ½ OD ½ long, flanged

2 – 5/8 ID ¾ OD ½ long

Plastic Ball Knobs

2 – 1 ¾ dia. ¾ -16 thread

Square key

2 – 1/8 x 7/8 long

Socket Head Cap Screws

2 – 8-32 x ¾

6 – ¼-20 x ½

33 – ¼-20 x ¾

6 – ¼ - 20 x 7/8

4 – ¼-20 x 1 ¼

2 – ¾-16 x 1

Set Screw

4 – 10-32 X ¼ in long

Eye Bolt

2 - 1 in. eye 5/16 – 18 x 1 in. thread

Rubber Hose

2 – 5/8 ID x 4 long

11a – Foot Side

1 – Handle

2 – Bend Over Platen

3 – Bottom Support

7 – Clamp Plate

8 – Clamp Rocker

9 – Clamp Support

10 – Clamp Cam Follower

11b – Foot Side

15 – Top Plate

13 – Side Plate

14 – Thickness Adjustor

16 – Dowel

5 - Lever

4 – Cam Adjuster

5 – Cam

12 - Reach Shaft

17 – Cam Stop

JRW Sheet Metal Brake



Copyright (C) 2004
R. J. Kostelnicek
J. R. Williams.
All rights reserved.

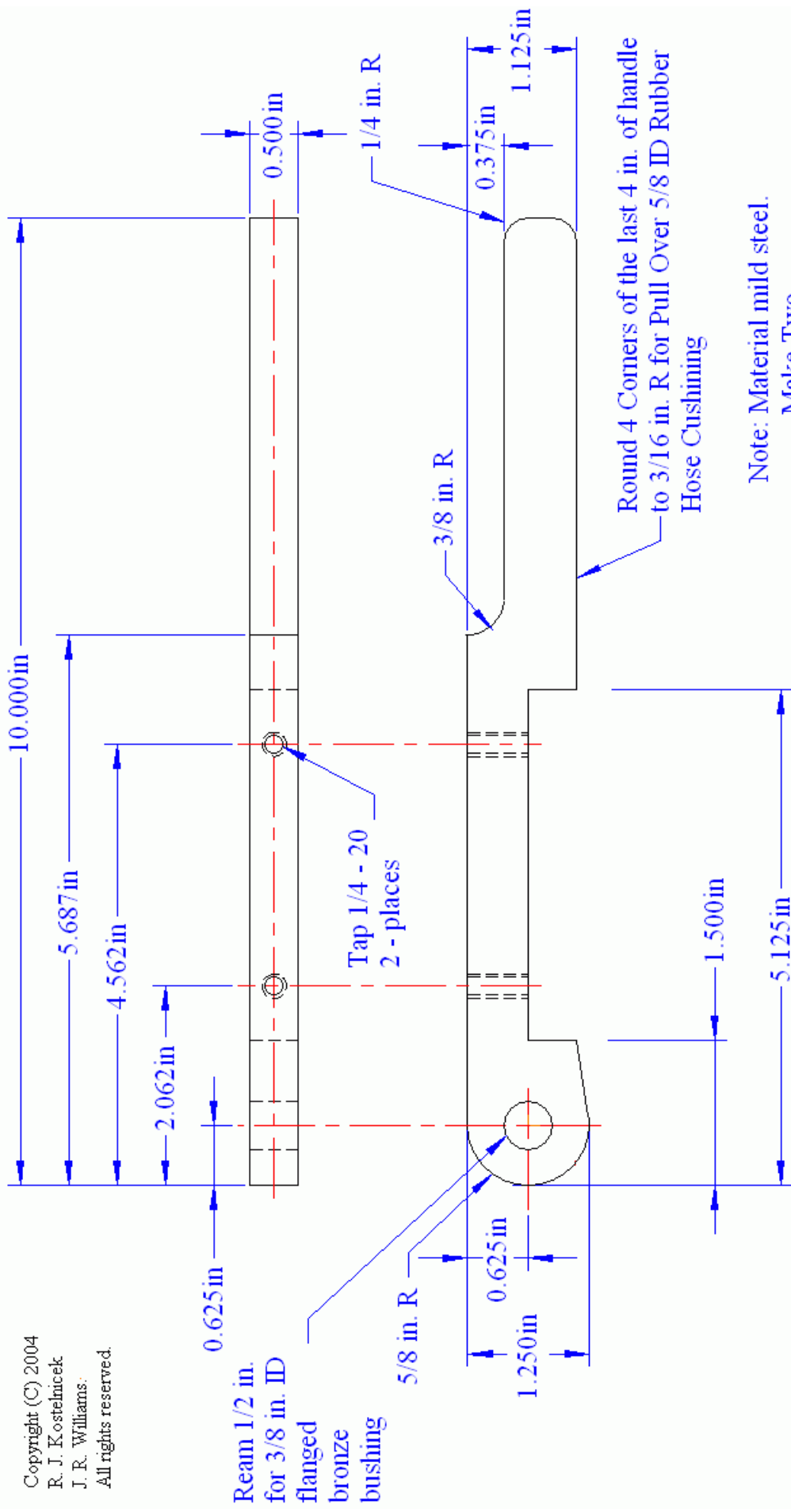

1 - Handle JRW Sheet Metal Brake

Designed by J. R. Williams - Drawn & Modified by R. J. Kostelnicek - 04/24/04

Copyright (C) 2004
R. J. Kostelnicek
J. R. Williams.
All rights reserved.

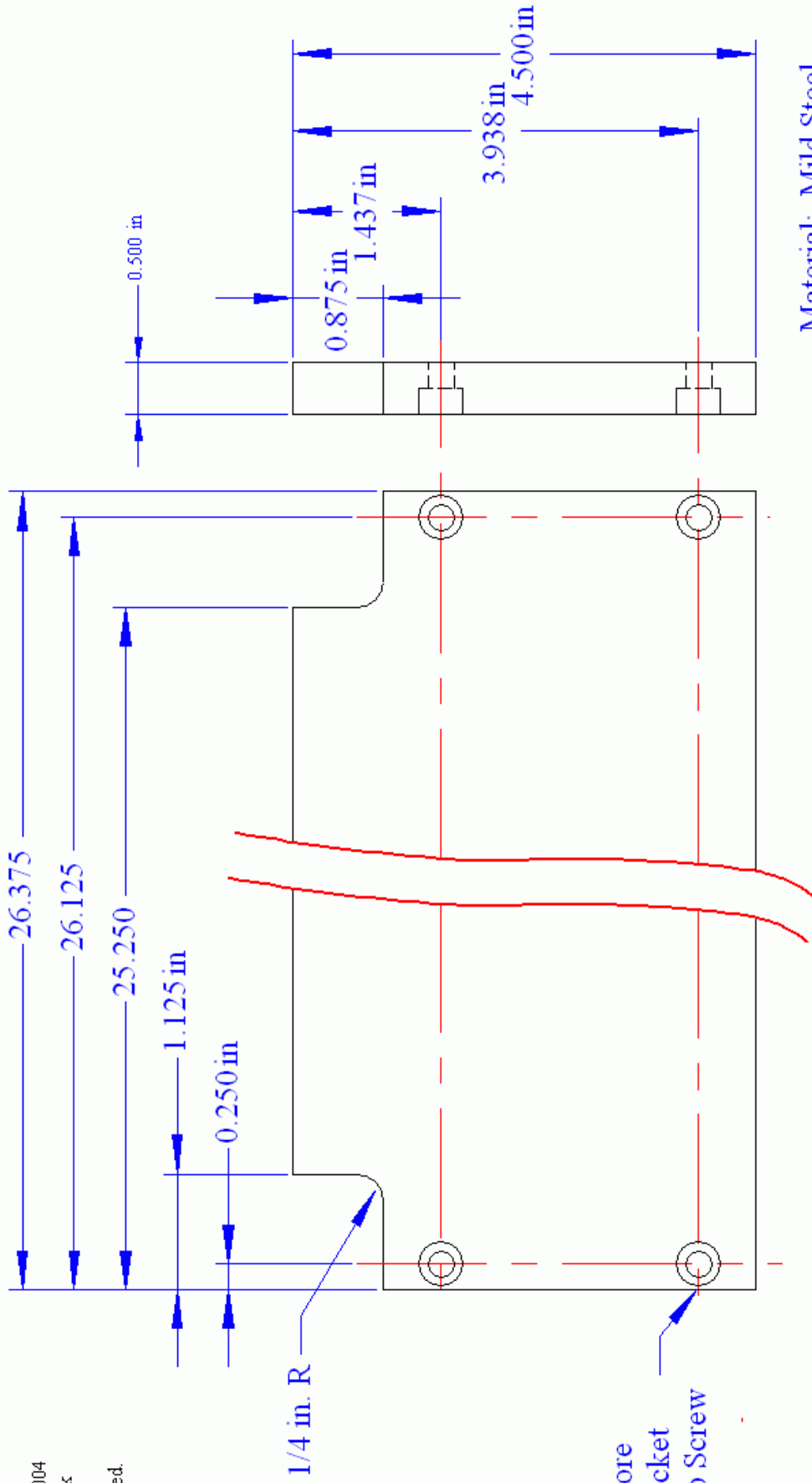

Material: Mild Steel

2 - Bend Over Platen JRW Sheet Metal Brake

Designed by J. R. Williams - Drawn & Modified by R. J. Kostelnicek - 04/24/04

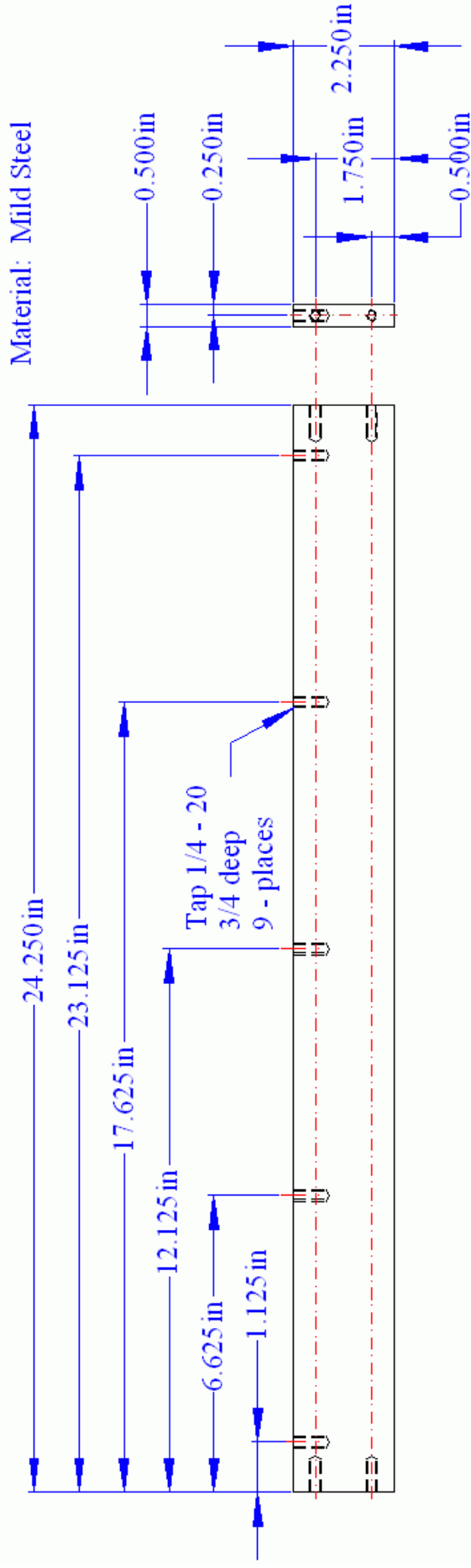

3 - Bottom Support JRW Sheet Metal Brake

Designed by J. R. Williams - Drawn & Modified by R. J. Kostelnicek - 04/24/04

Copyright (C) 2004
R. J. Kostelnicek
J. R. Williams.
All rights reserved.

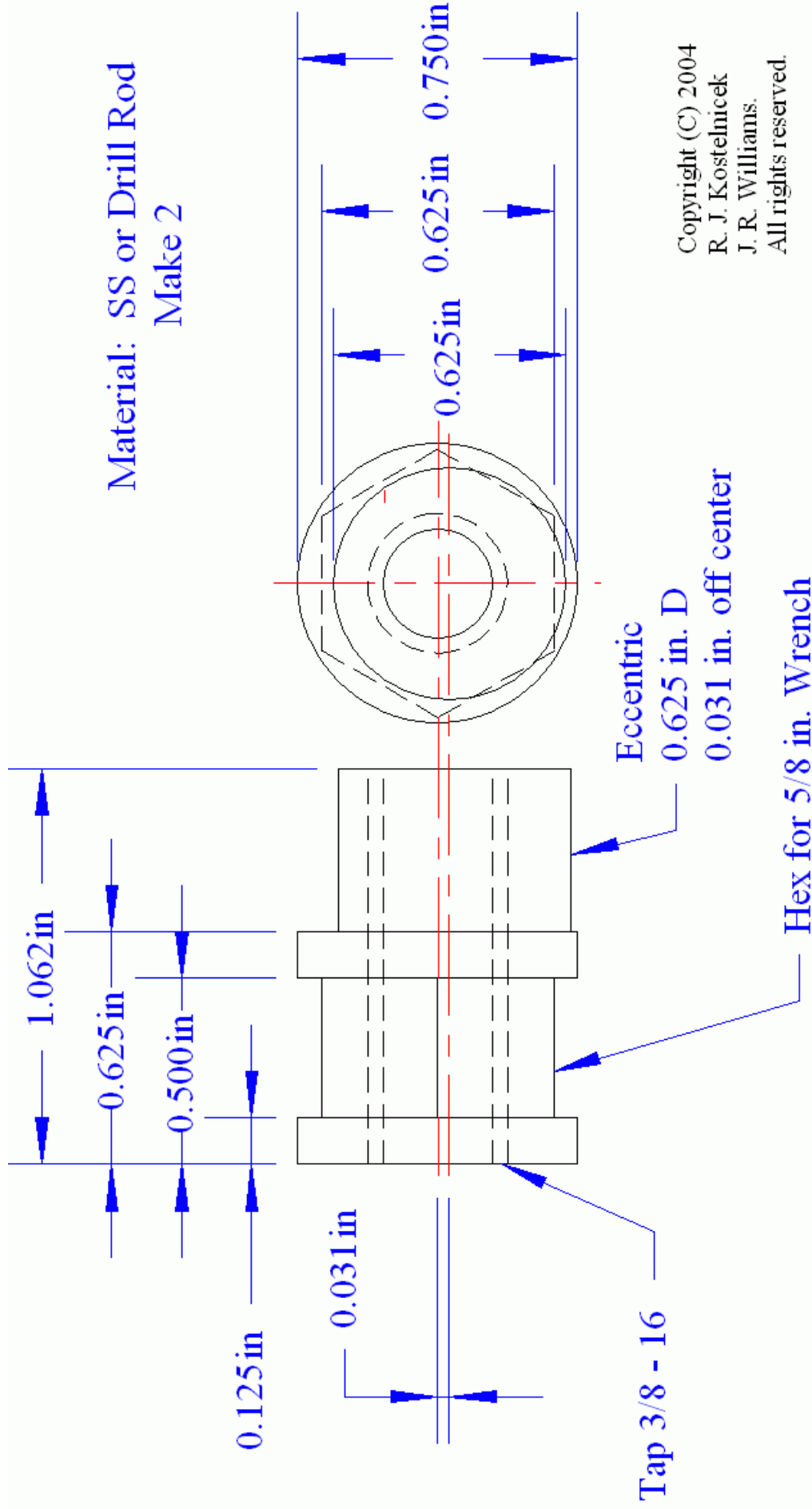

Copyright (C) 2004
R. J. Kostelnicek
J. R. Williams.
All rights reserved.

4 - Cam Adjuster JRW Sheet Metal Brake

Designed by J. R. Williams - Drawn & Modified by R. J. Kostelnicek - 04/24/04

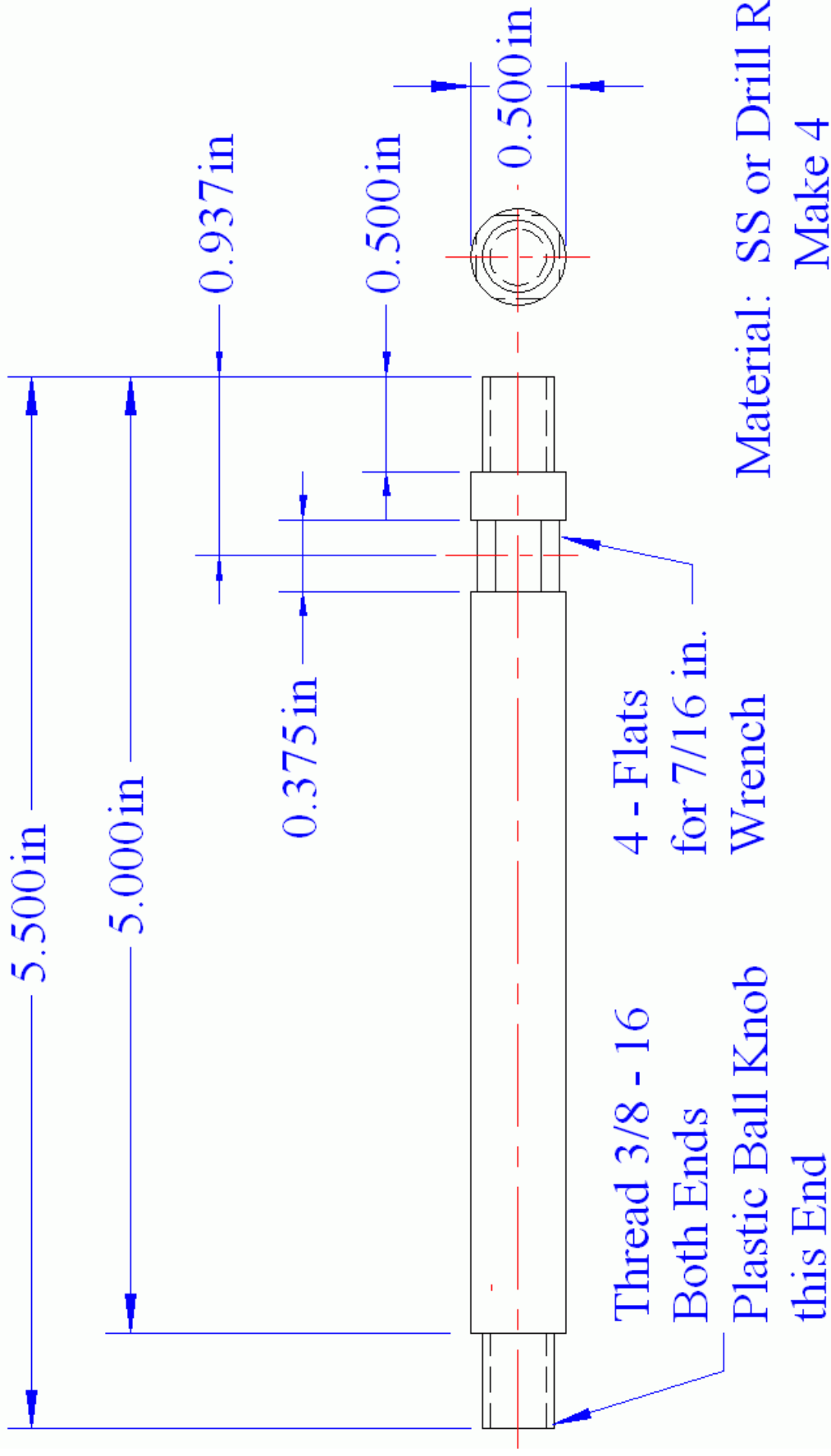

5 - Lever JRW Sheet Metal Brake

Designed by J. R. Williams - Drawn & Modified by R. J. Kostelnicek - 04/24/04

Copyright (C) 2004
R. J. Kostelnicek
J. R. Williams.
All rights reserved.

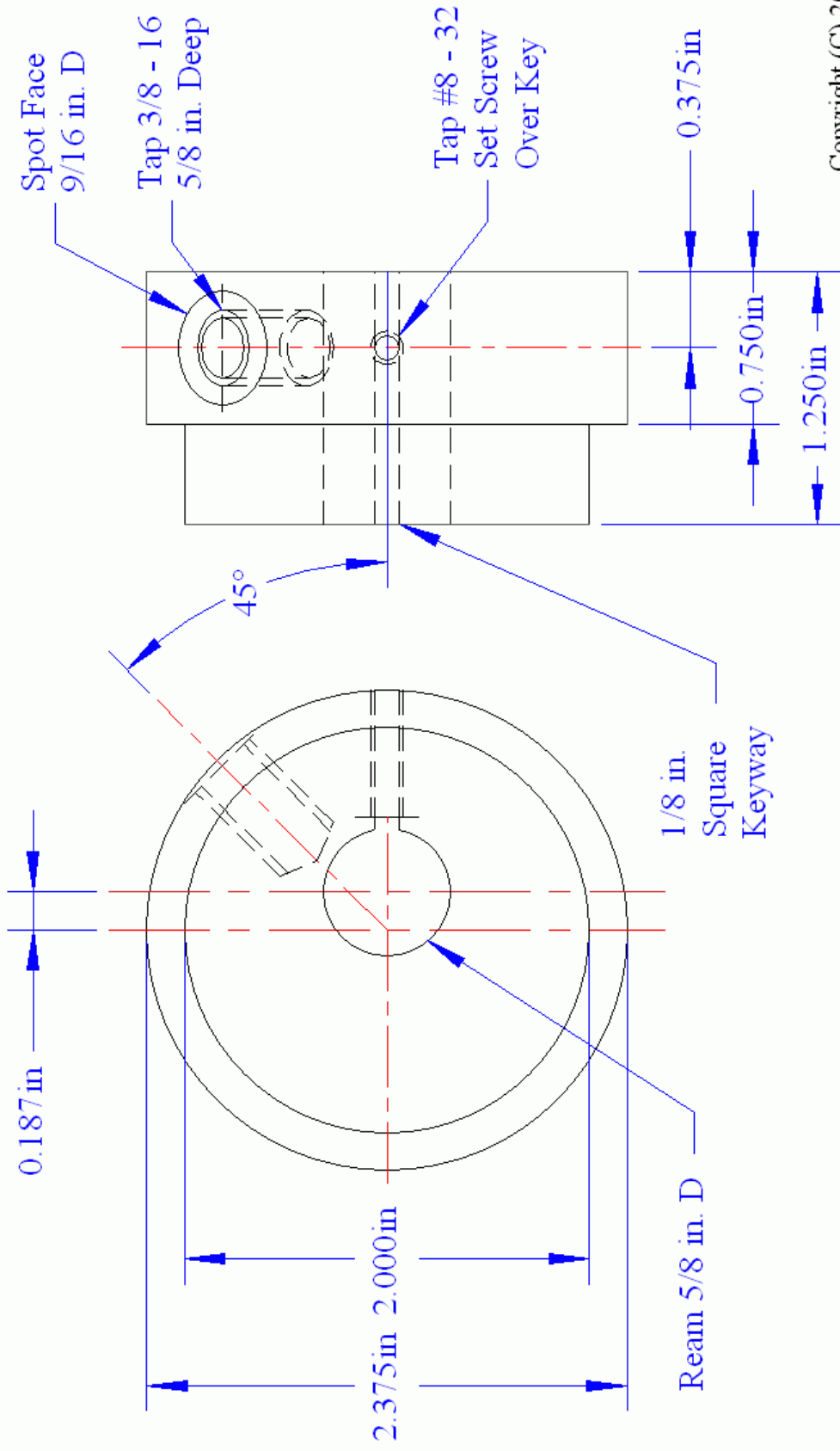

Material: Mild Steel
 Make Right and Left Hand

Copyright (C) 2004
 R. J. Kostelnicek
 J. R. Williams.
 All rights reserved.

6 - Cam JRW Sheet Metal Brake

Designed by J. R. Williams - Drawn & Modified by R. J. Kostelnicek - 04/24/04

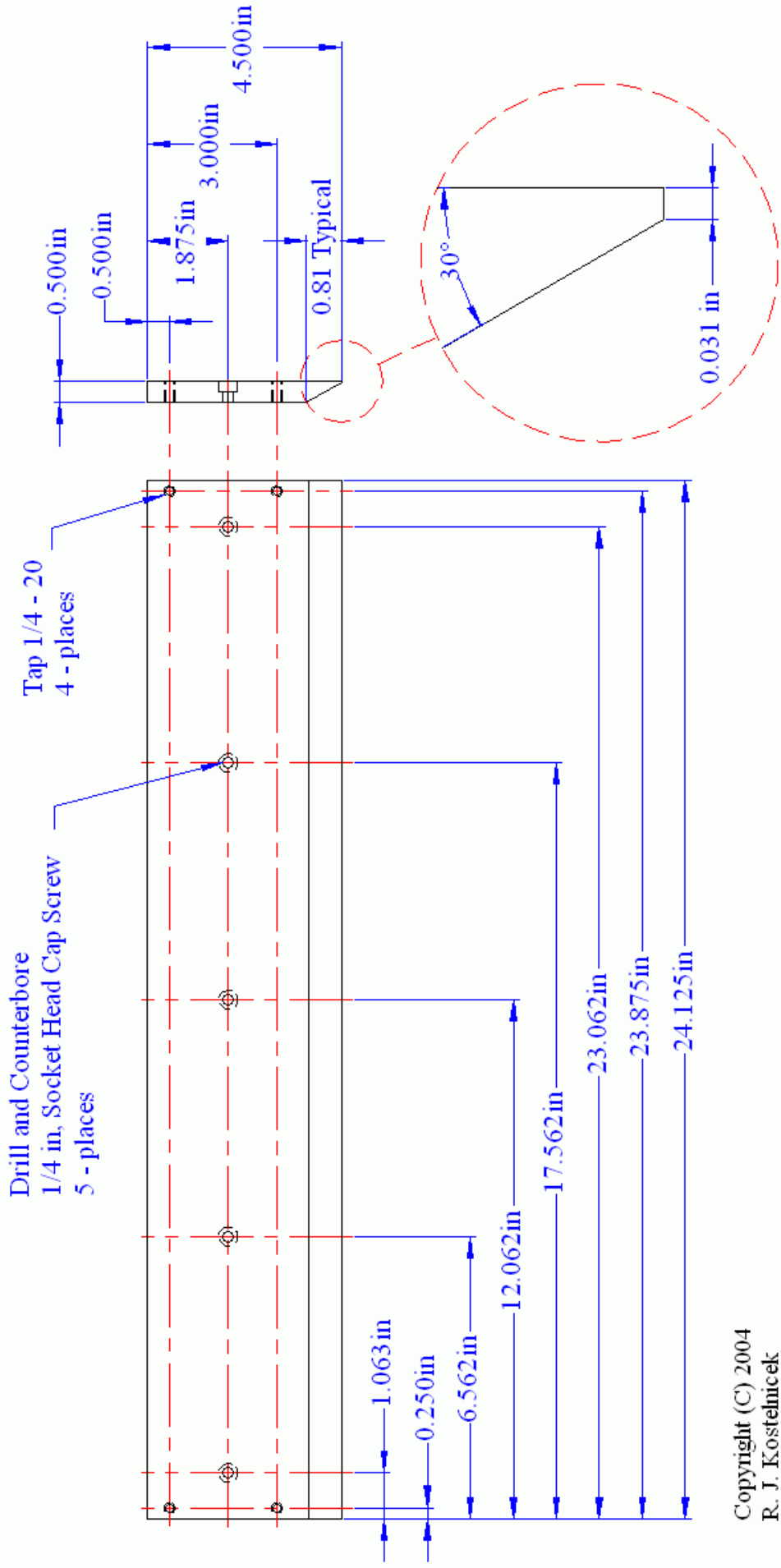

Copyright (C) 2004
R. J. Kostelnicek
J. R. Williams.
All rights reserved.

Material: Mild Steel

7 - Clamp Plate JRW Sheet Metal Brake

Designed by J. R. Williams - Drawn & Modified by R. J. Kostelnicek - 04/24/04

Copyright (C) 2004
 R. J. Kostelnicek
 J. R. Williams.
 All rights reserved.

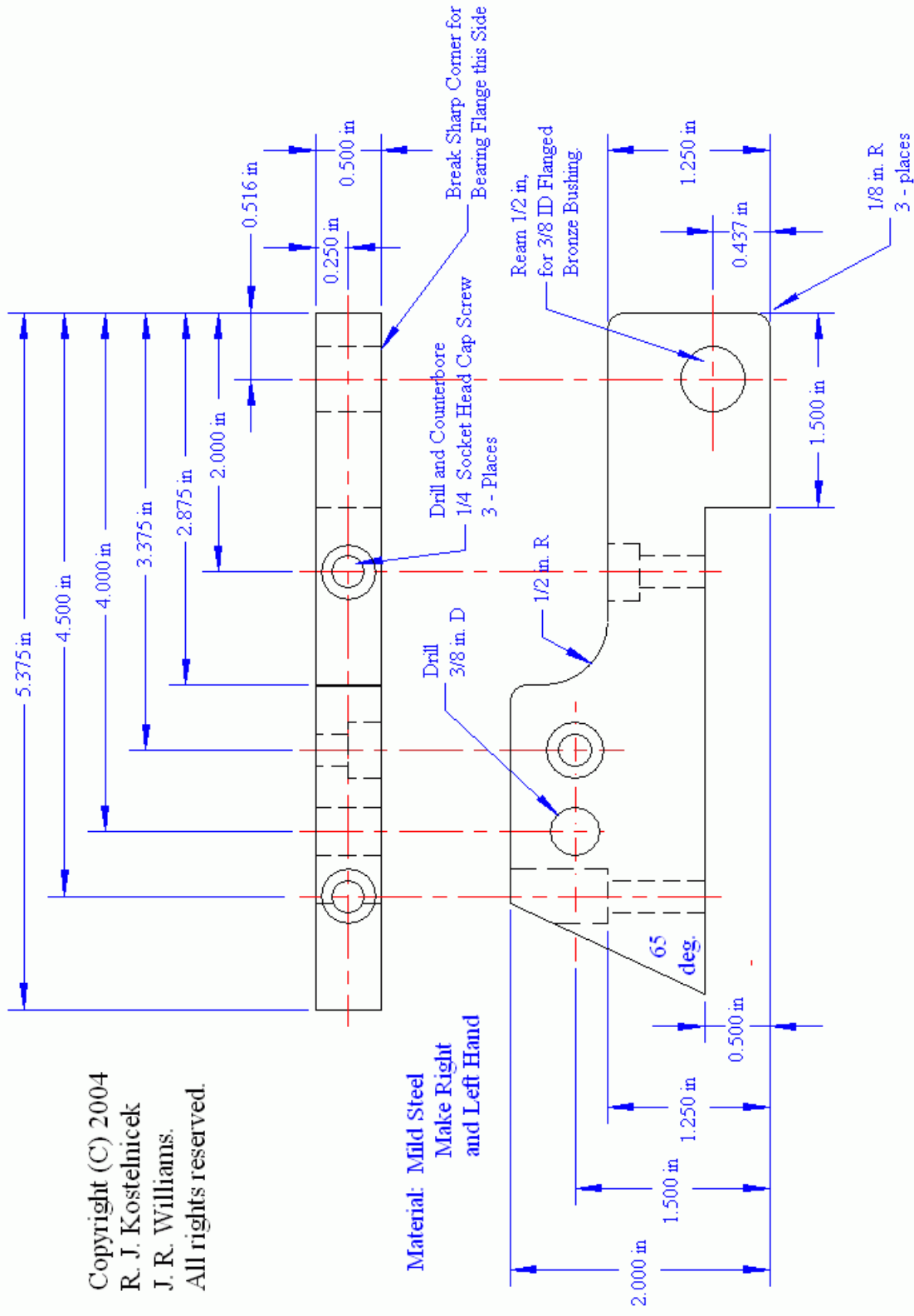

8 - Clamp Rocker JRW Sheet Metal Brake

Designed by J. R. Williams - Drawn & Modified by R. J. Kostelnicek - 04/24/04

Tap 5/15 - 18
 1 - in. deep
 2 - places
 for Lifting Eye Bolt

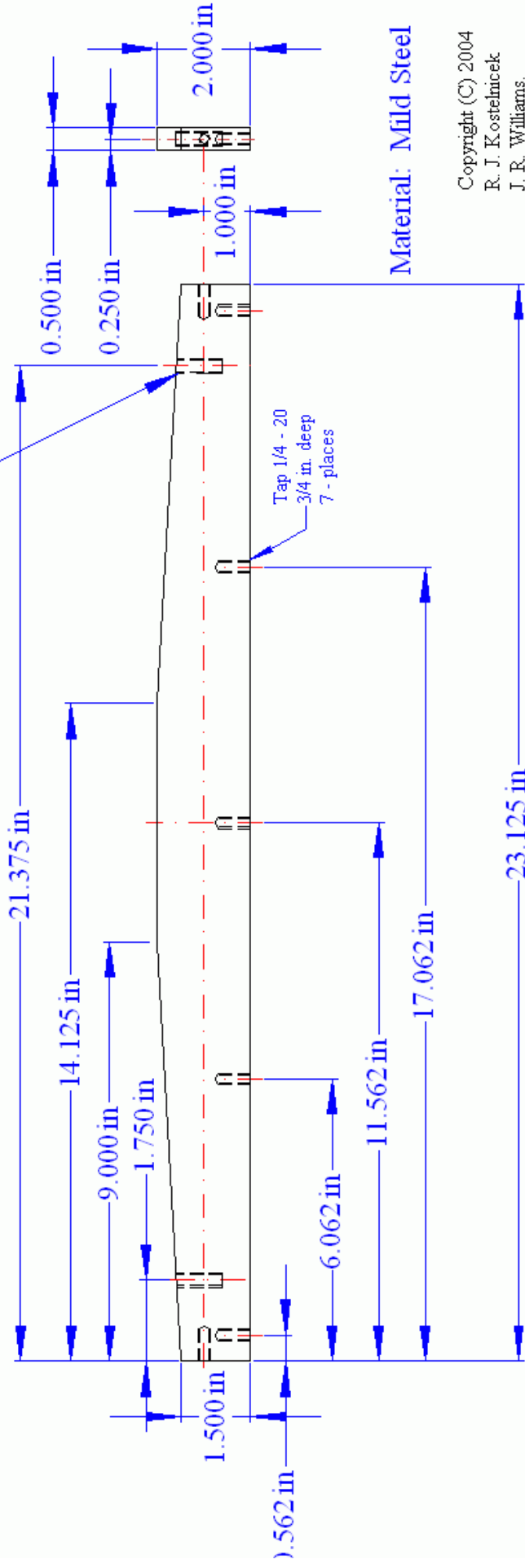

Material: Mild Steel

Copyright (C) 2004
 R. J. Kostelnicek
 J. R. Williams.
 All rights reserved.

9 - Clamp Support JRW Sheet Metal Brake

Designed by J. R. Williams - Drawn by R. J. Kostelnicek - 04/24/04

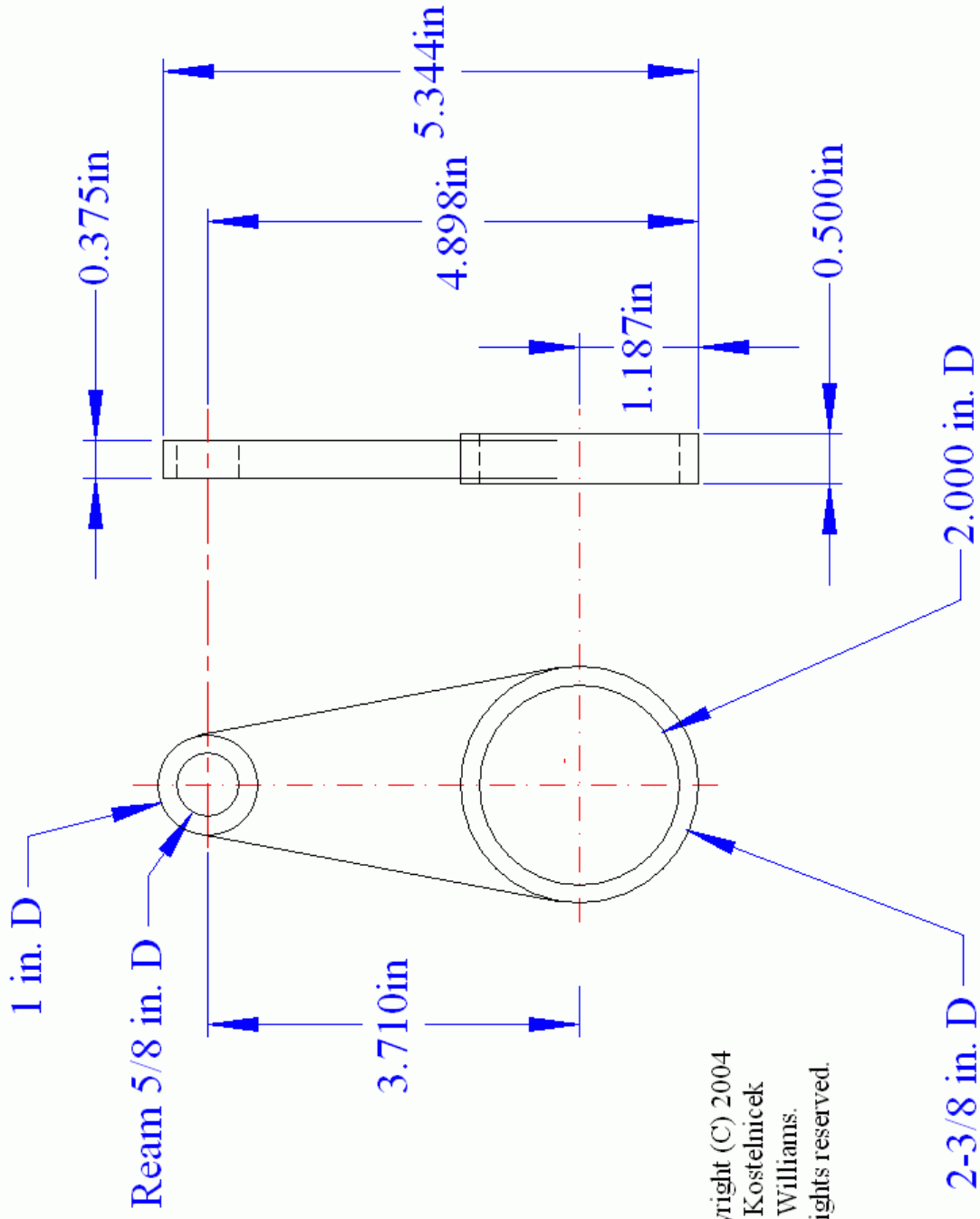

Copyright (C) 2004
 R. J. Kostelnicek
 J. R. Williams.
 All rights reserved.

10 - Clamp Cam Follower JRW Sheet Metal Brake

Designed by J. R. Williams - Drawn & Modified by R. J. Kostelnicek - 04/24/04

11a - Foot Side

Copyright (C) 2004
 R. J. Kostelnicek
 J. R. Williams.
 All rights reserved.

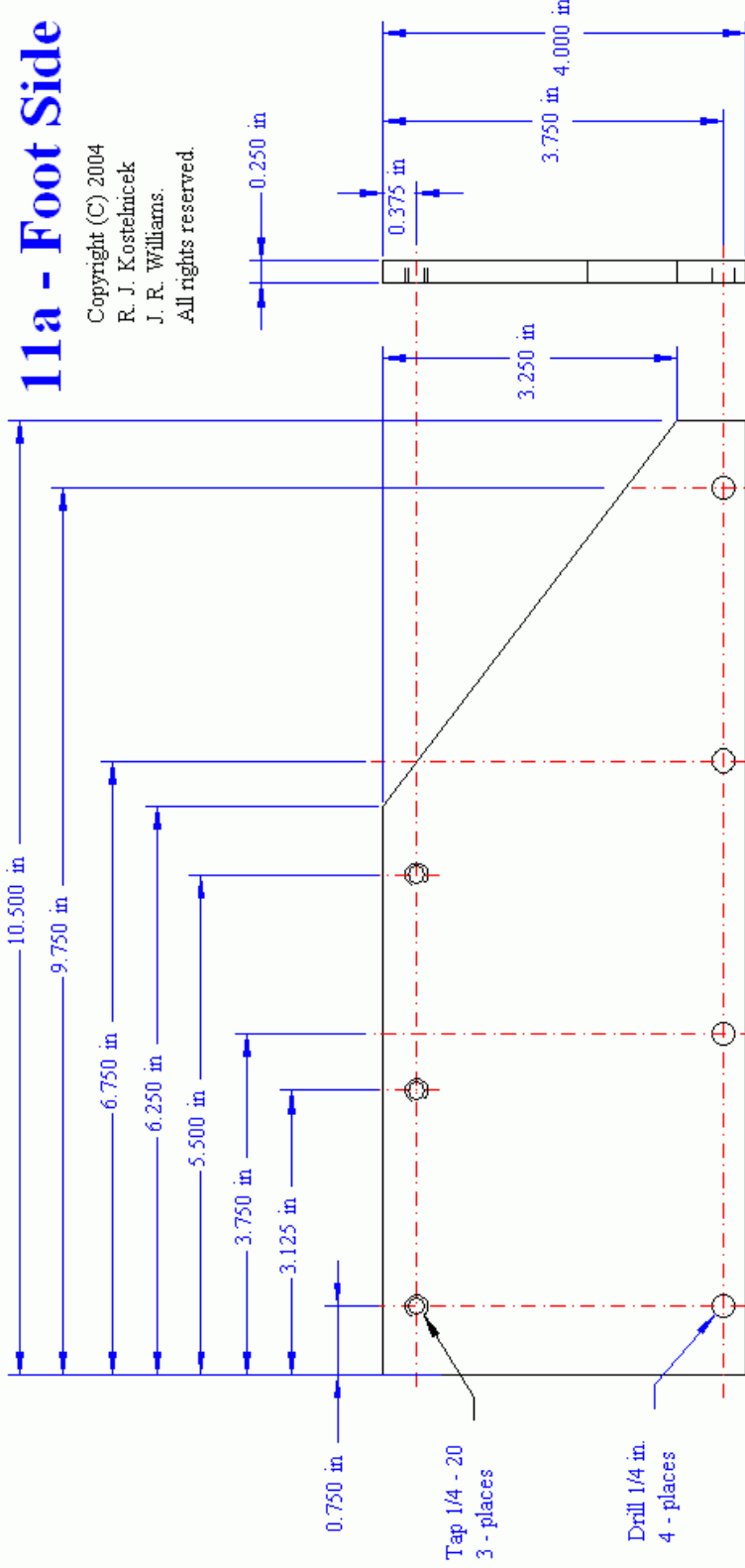

Material: Mild Steel
 Make 2 Each

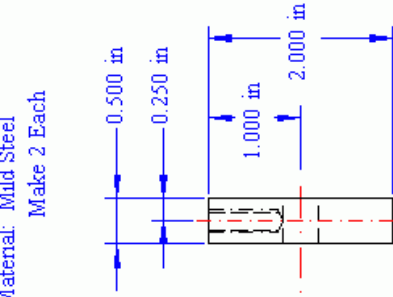

11b - Foot Bottom

Designed by J. R. Williams - Drawn & Modified by R. J. Kostelnicek - 04/24/04

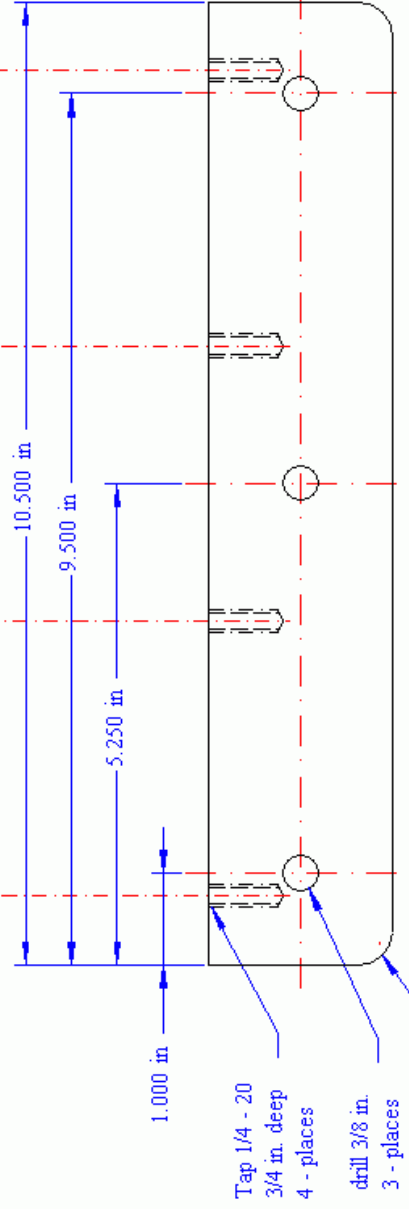

Tap 1/4 - 20
 3/4 in. deep
 4 - places
 drill 3/8 in.
 3 - places
 3/8 in. R

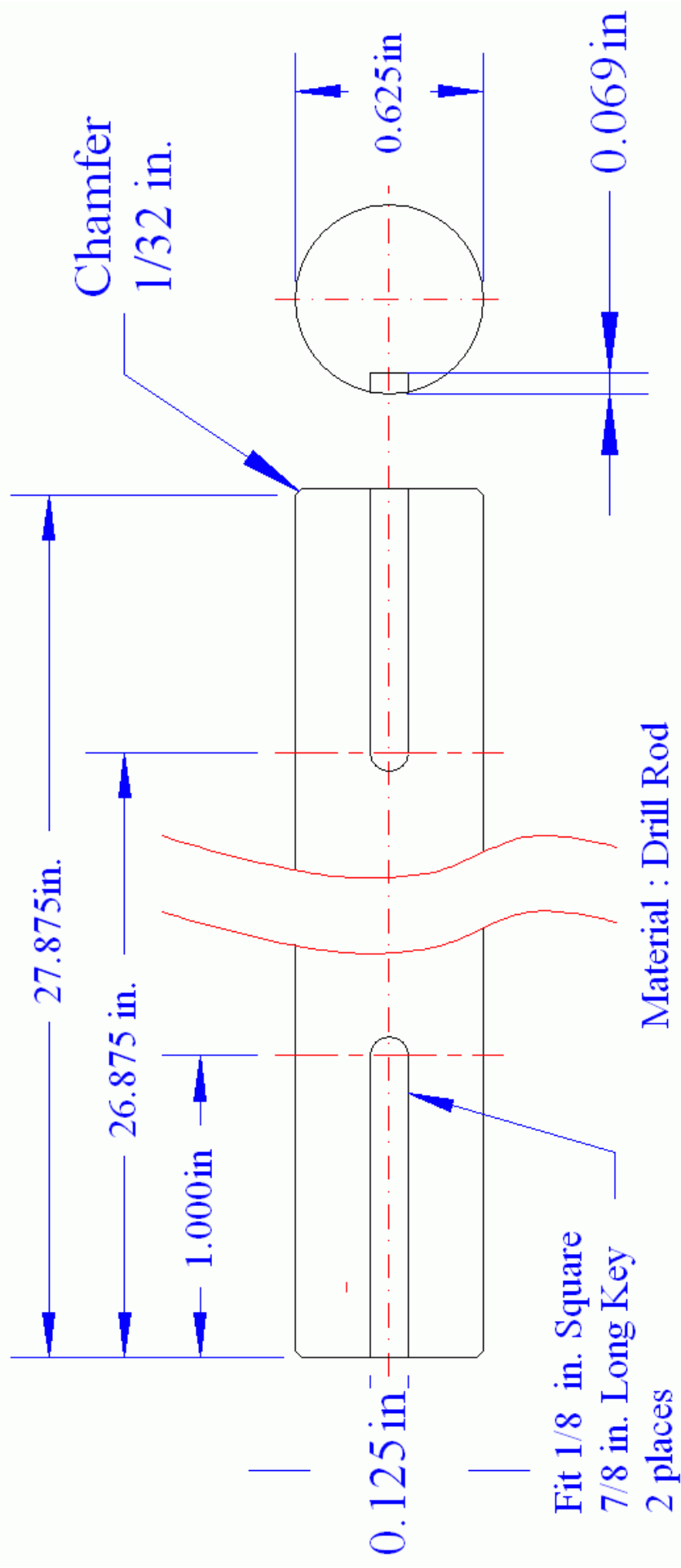

Fit 1/8 in. Square
 7/8 in. Long Key
 2 places

12 - Reach Shaft JRW Sheet Metal Brake

Copyright (C) 2004
 R. J. Kostelnicek
 J. R. Williams.
 All rights reserved.
 Designed by J. R. Williams - Drawn & Modified by R. J. Kostelnicek - 04/24/04

Copyright (C) 2004
 R. J. Kostelnicek
 J. R. Williams
 All rights reserved.

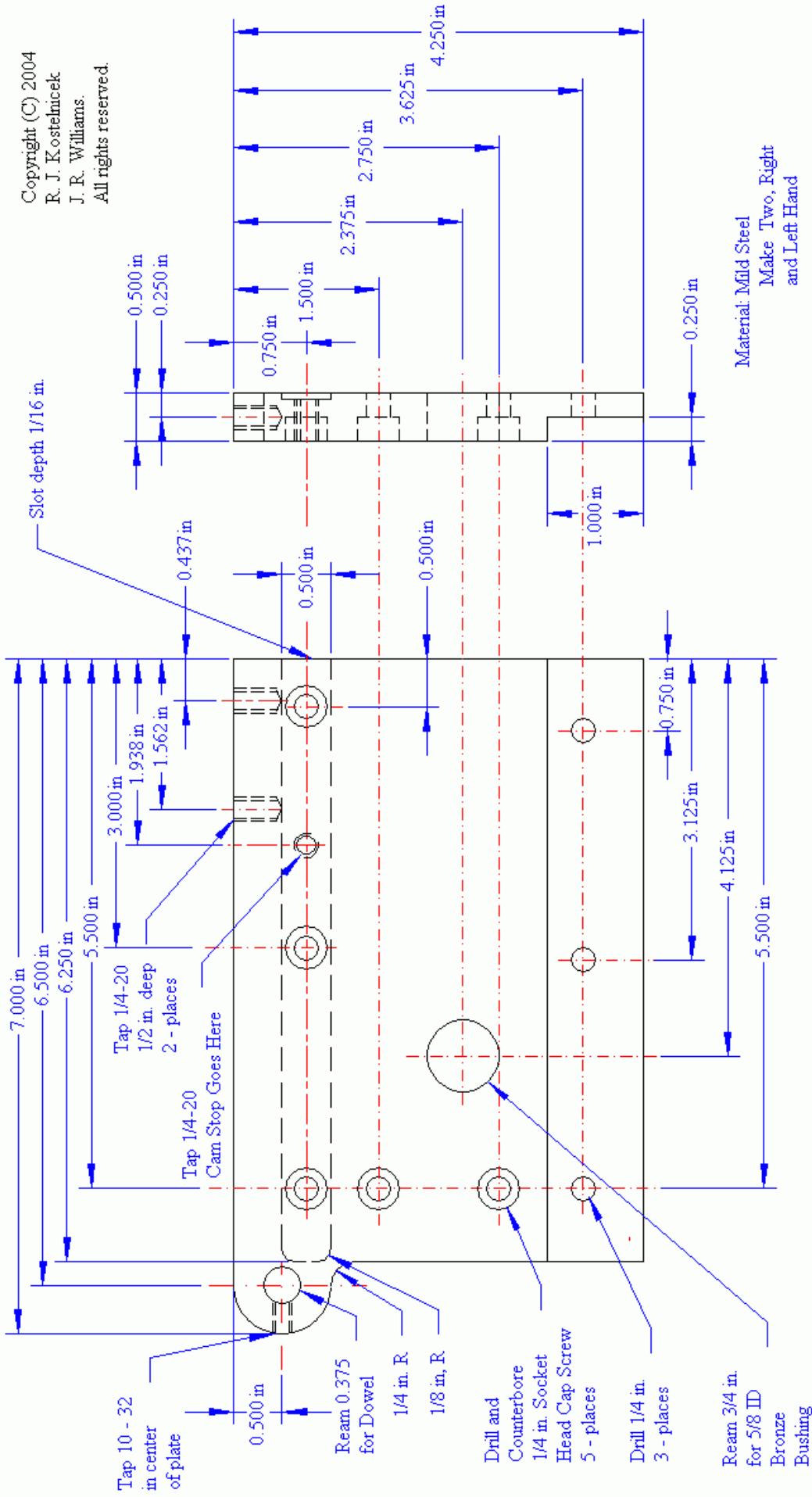

13 - Side Plate JRW Sheet Metal Brake

Designed by J. R. Williams - Drawn & Modified by R. J. Kostelnicek - 04/24/04

Copyright (C) 2004
 R. J. Kostelnicek
 J. R. Williams.
 All rights reserved.

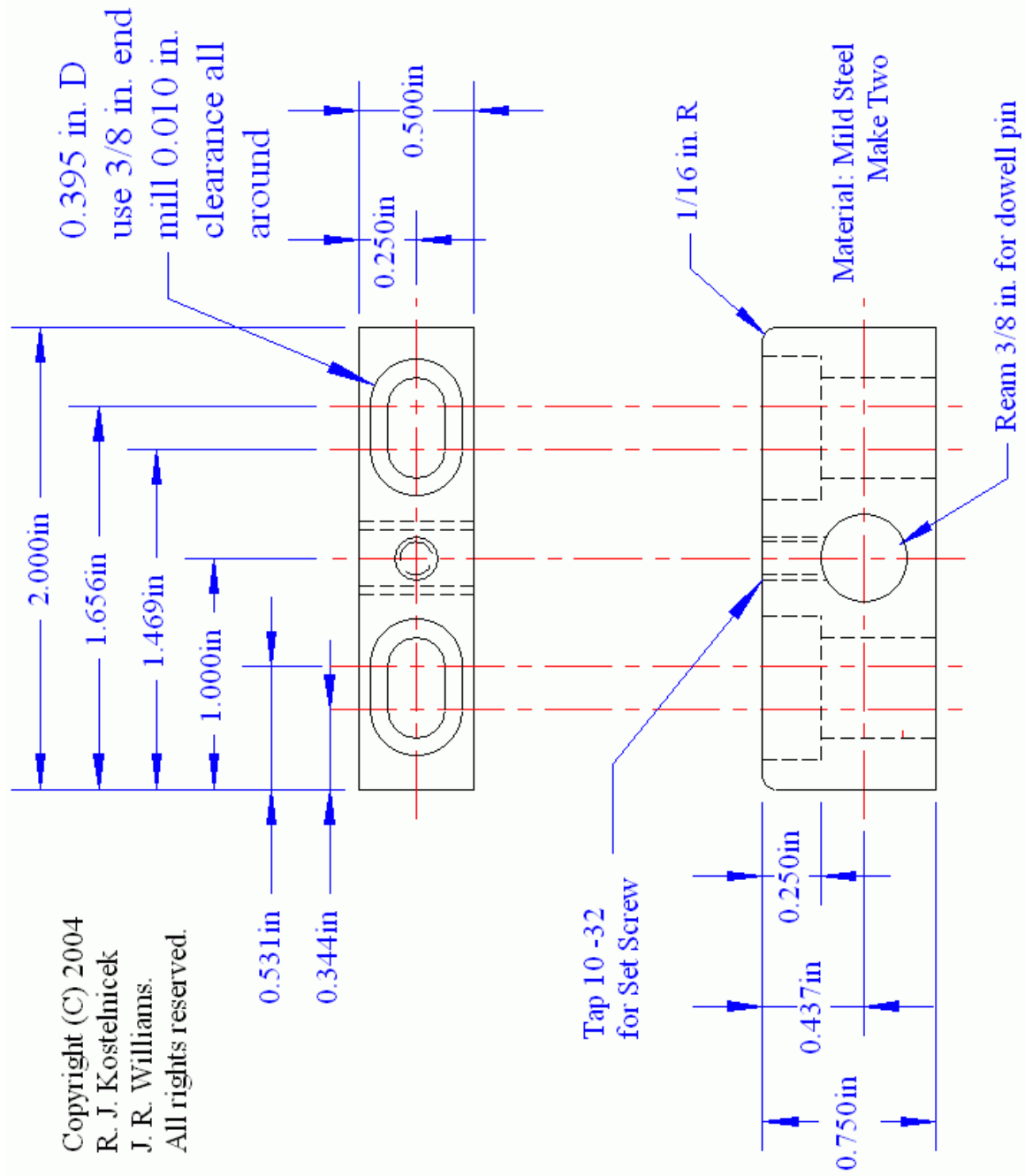

14 - Thickness Adjustor JRW Sheet Metal Brake

Designed by J. R. Williams - Drawn & Modified by R. J. Kostelnicek - 04/24/04

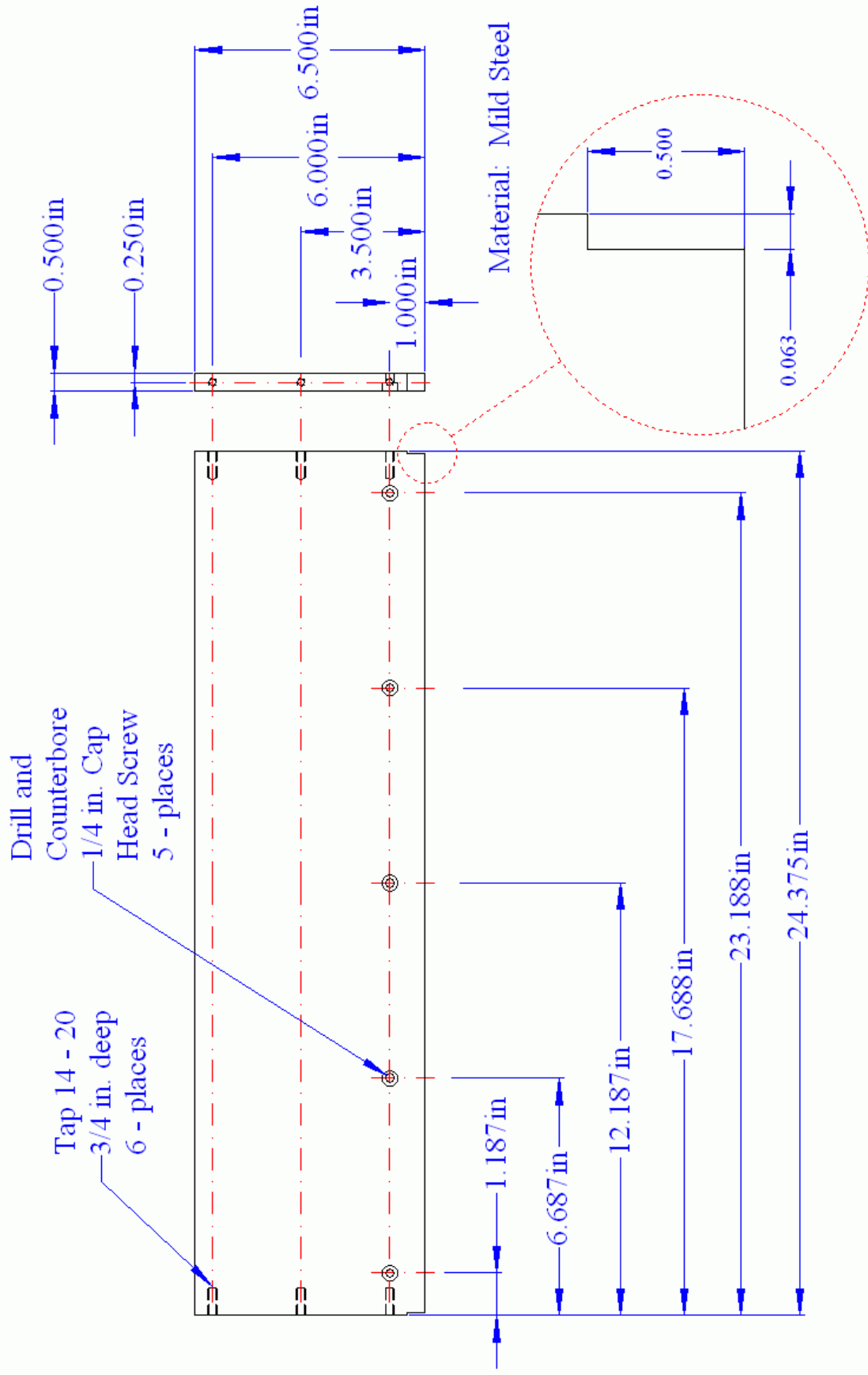

15 - Top Plate JRW Sheet Metal Brake

Designed by J. R. Williams - Drawn & Modified by R. J. Kostelnicek - 04/24/04

Copyright (C) 2004
 R. J. Kostelnicek
 J. R. Williams.
 All rights reserved.

Copyright (C) 2004
R. J. Kostelnicek
J. R. Williams.
All rights reserved.

Material: SS or Drill Rod
Make 4

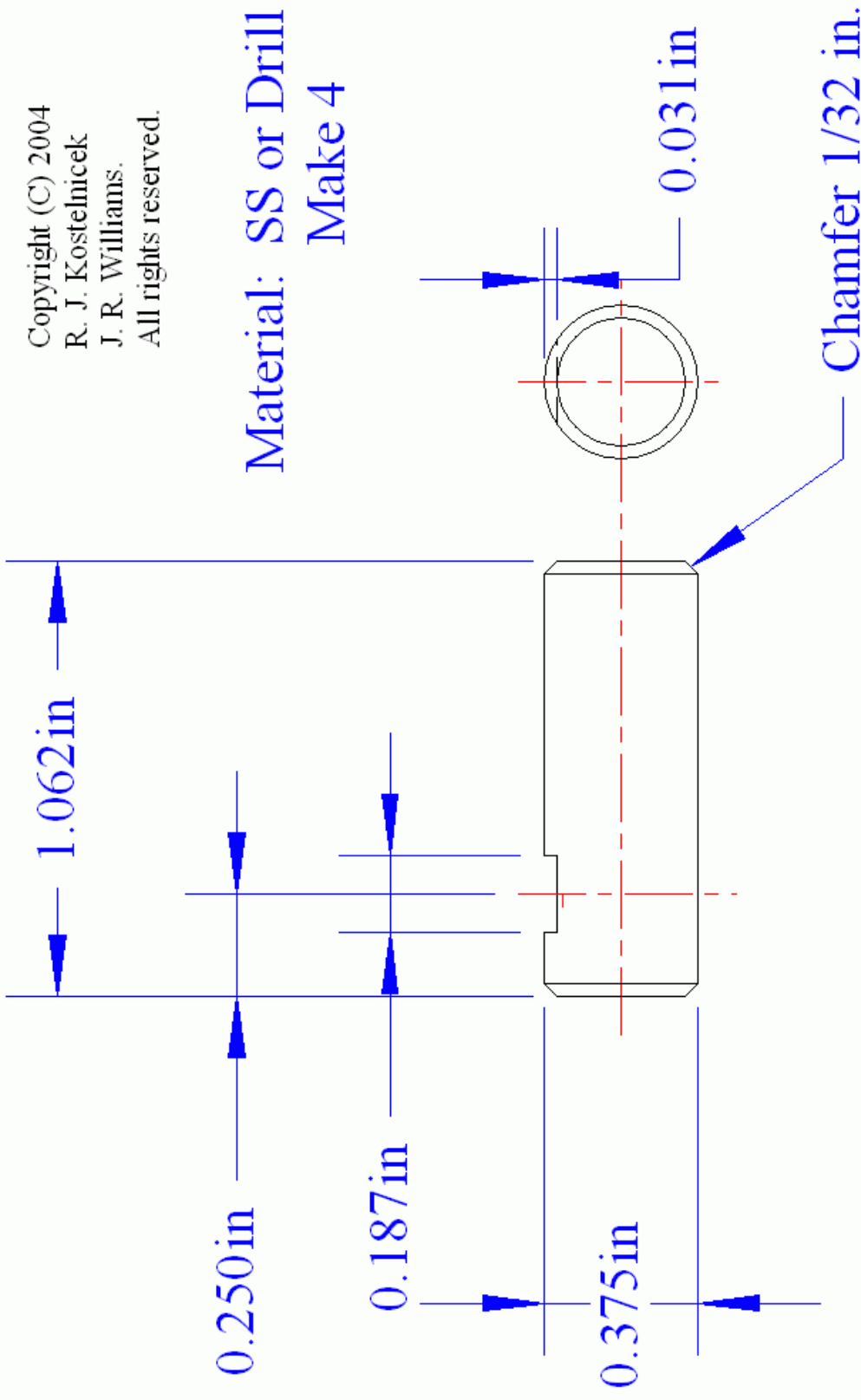

16 - Dowel JRW Sheet Metal Brake

Designed by J. R. Williams - Drawn & Modified by R. J. Kostelnicek - 04/24/04

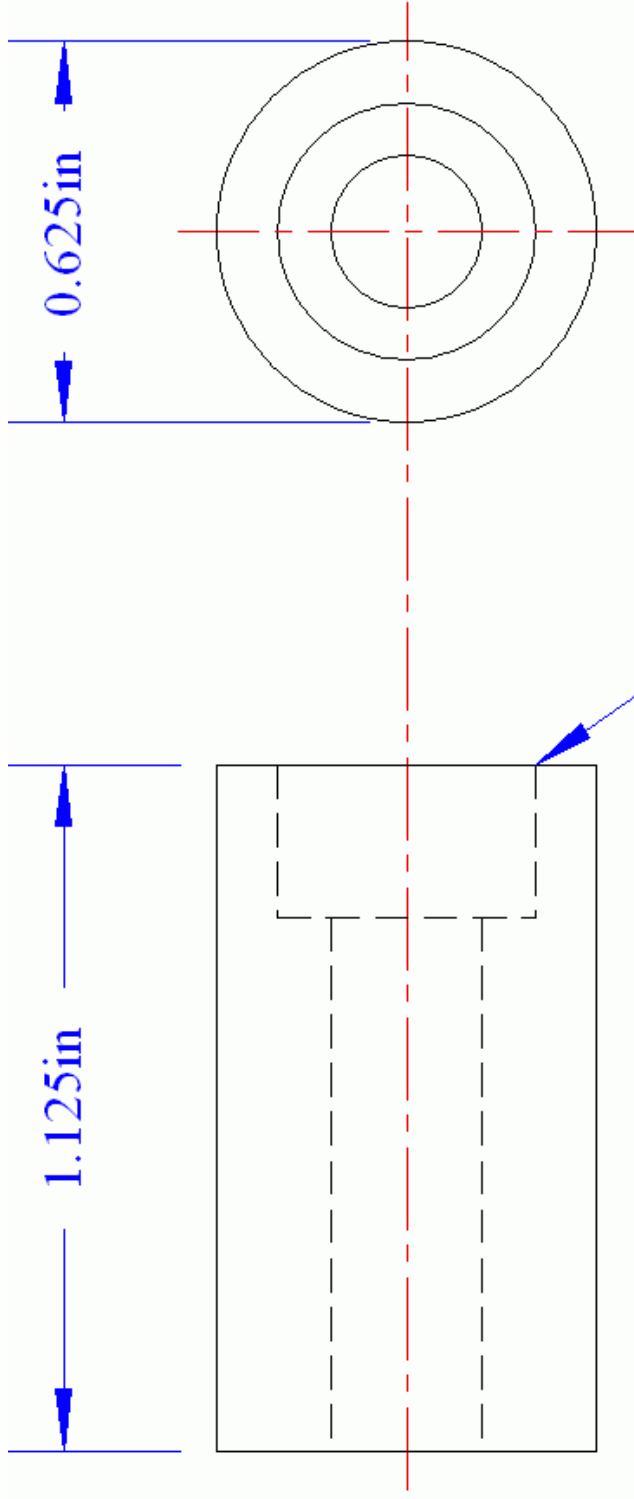

Material: SS or Drill Rod
Make 2

Copyright (C) 2004
 R. J. Kostelnicek
 J. R. Williams.
 All rights reserved.

**Drill and
 Counterbore
 1/4 in. Socket
 Head Cap Screw**

17 - Cam Stop JRW Sheet Metal Brake

Designed by J. R. Williams - Drawn & Modified by R. J. Kostelnicek - 04/24/04