



Adjustable Tool Grinder

by Martin Kennedy
July 7, 2014

PROPRIETARY AND CONFIDENTIAL

THE INFORMATION CONTAINED IN THIS DRAWING IS THE SOLE PROPERTY OF MARTIN KENNEDY. ANY REPRODUCTION, FOR OTHER THAN PERSONAL USE, IN PART OR AS A WHOLE WITHOUT EXPRESS PERMISSION IS PROHIBITED.

SIZE A	FILE NAME Tool Grinder Drawings	REV. A
SCALE 1:3	Cover	SHEET 1 OF 21

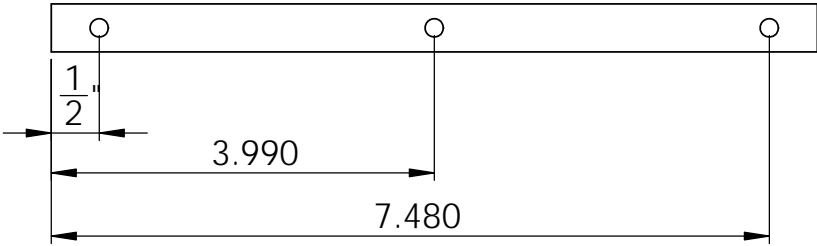
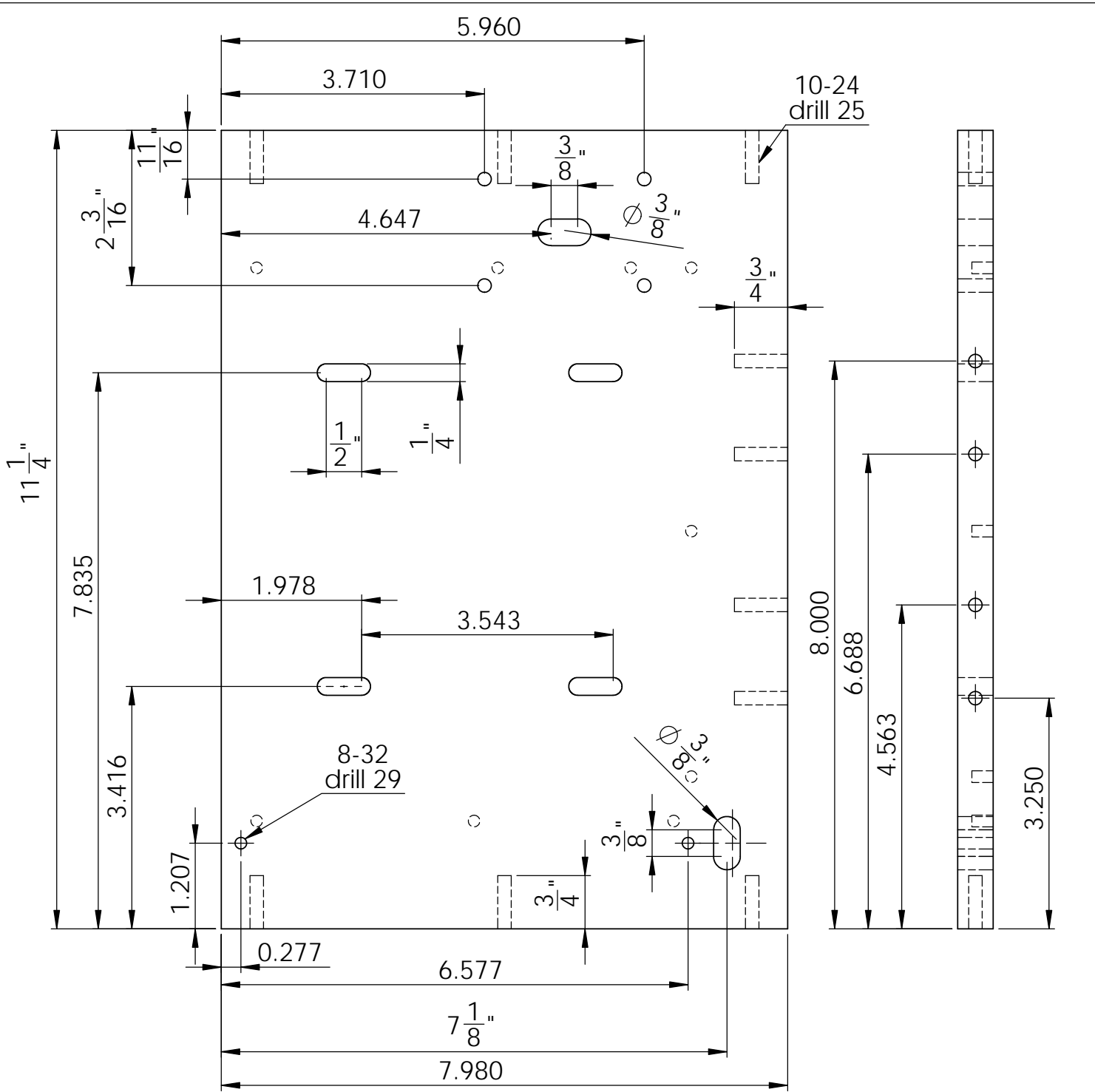

PROPRIETARY AND CONFIDENTIAL
 THE INFORMATION CONTAINED IN THIS DRAWING IS THE SOLE PROPERTY OF MARTIN KENNEDY. ANY REPRODUCTION, FOR OTHER THAN PERSONAL USE, IN PART OR AS A WHOLE WITHOUT EXPRESS PERMISSION IS PROHIBITED.

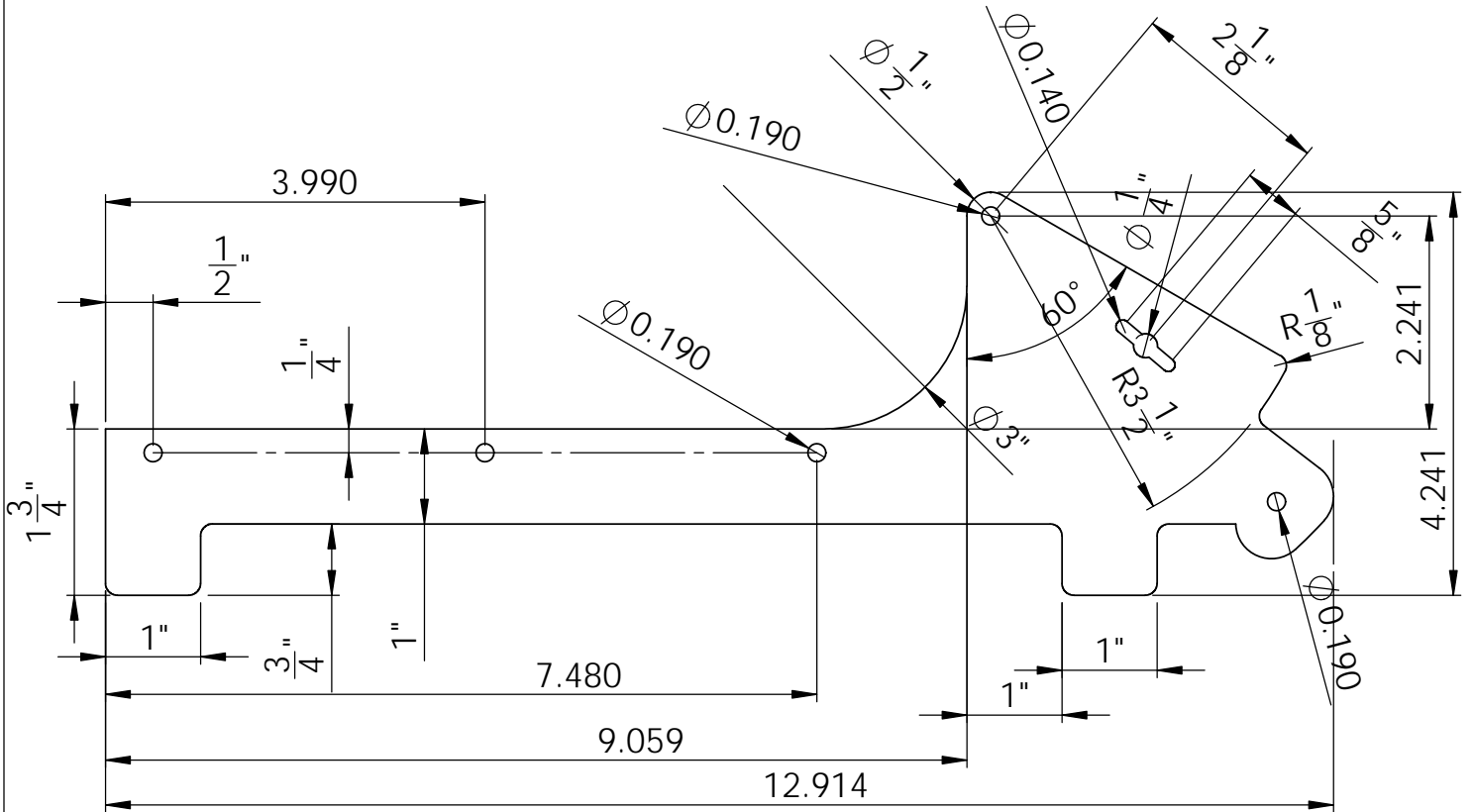

NOTE: One required. 1/4" plate

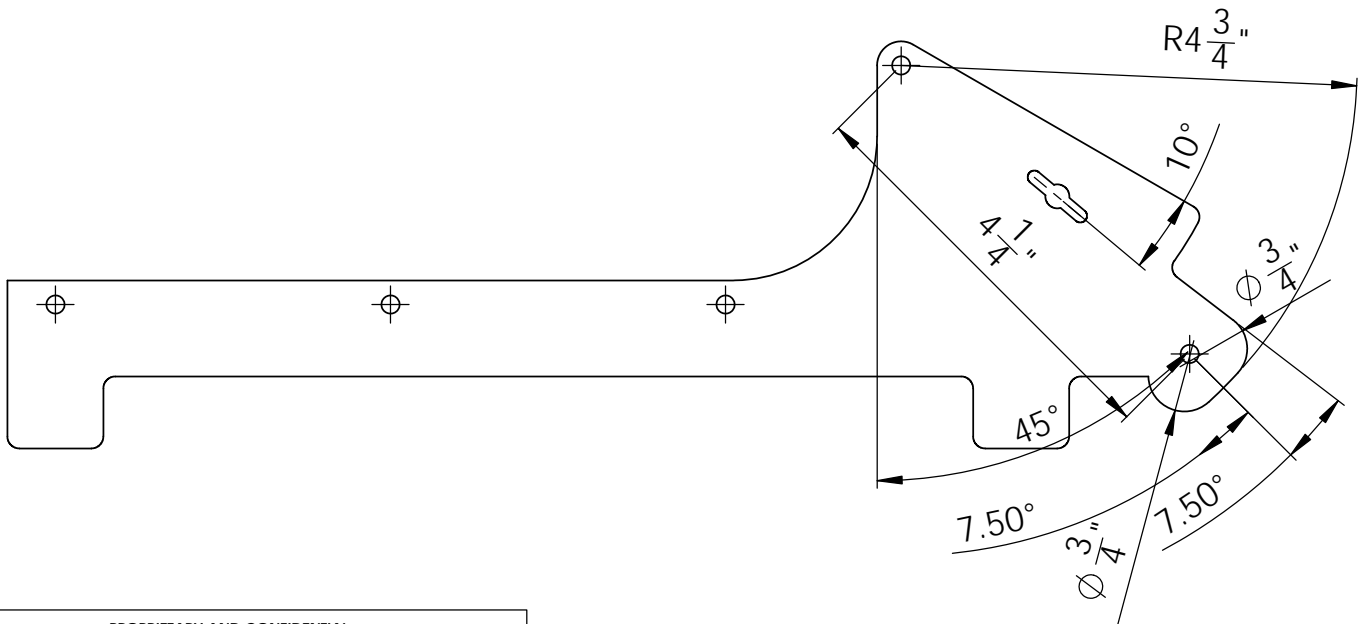

PROPRIETARY AND CONFIDENTIAL

THE INFORMATION CONTAINED IN THIS DRAWING IS THE SOLE PROPERTY OF MARTIN KENNEDY. ANY REPRODUCTION, FOR OTHER THAN PERSONAL USE, IN PART OR AS A WHOLE WITHOUT EXPRESS PERMISSION IS PROHIBITED.

SIZE FILE NAME
A Tool Grinder Drawings

REV.
A

SCALE 1:2

Left Side

SHEET 3 OF 21

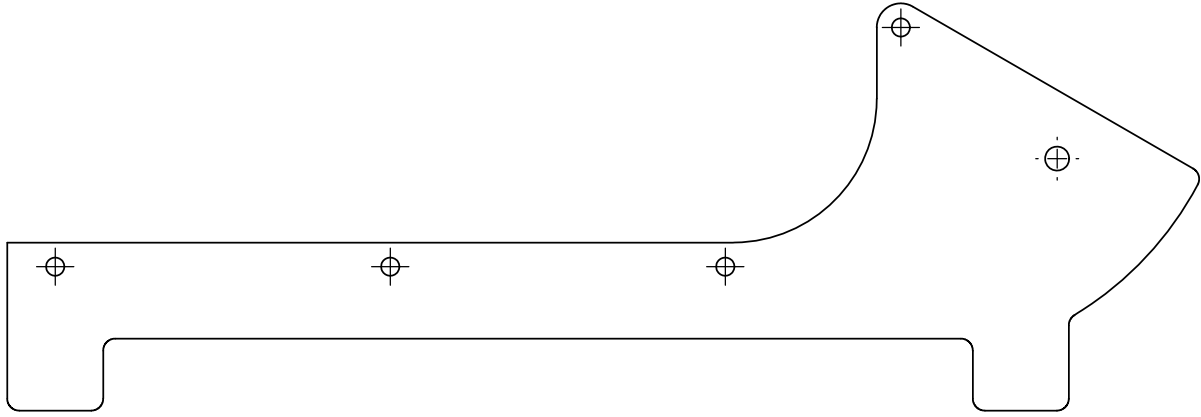

Note: See Left Side for dimensions

PROPRIETARY AND CONFIDENTIAL

THE INFORMATION CONTAINED IN THIS DRAWING IS THE SOLE PROPERTY OF MARTIN KENNEDY. ANY REPRODUCTION, FOR OTHER THAN PERSONAL USE, IN PART OR AS A WHOLE WITHOUT EXPRESS PERMISSION IS PROHIBITED.

SIZE A	FILE NAME Tool Grinder Drawings	REV. A
SCALE 1:2	Right Side	SHEET 4 OF 21

NOTE: Use 3/16 plate

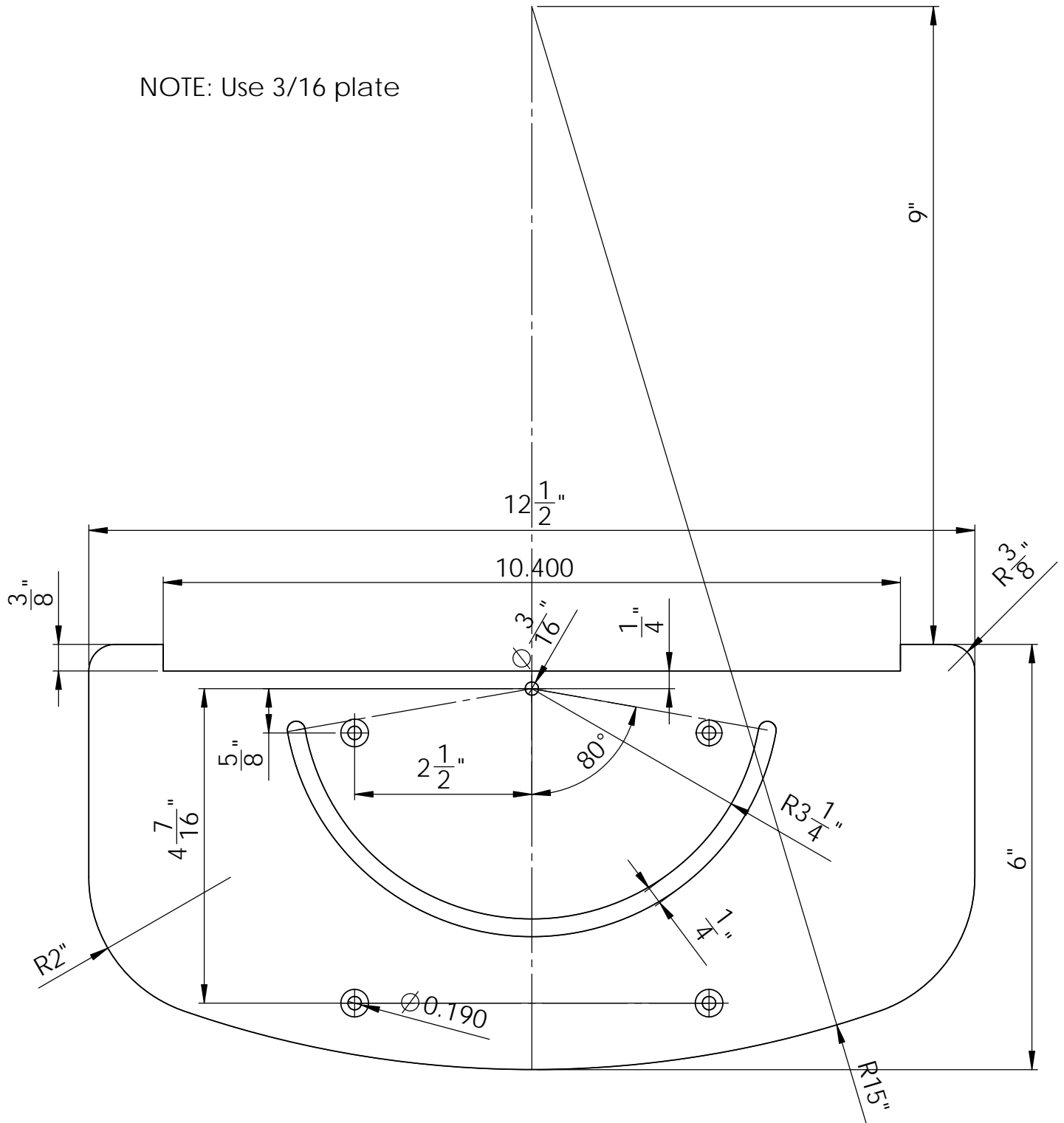

PROPRIETARY AND CONFIDENTIAL

THE INFORMATION CONTAINED IN THIS DRAWING IS THE SOLE PROPERTY OF MARTIN KENNEDY. ANY REPRODUCTION, FOR OTHER THAN PERSONAL USE, IN PART OR AS A WHOLE WITHOUT EXPRESS PERMISSION IS PROHIBITED.

SIZE FILE NAME
A Tool Grinder Drawings

REV.
A

SCALE 1:2

Table

SHEET 5 OF 21

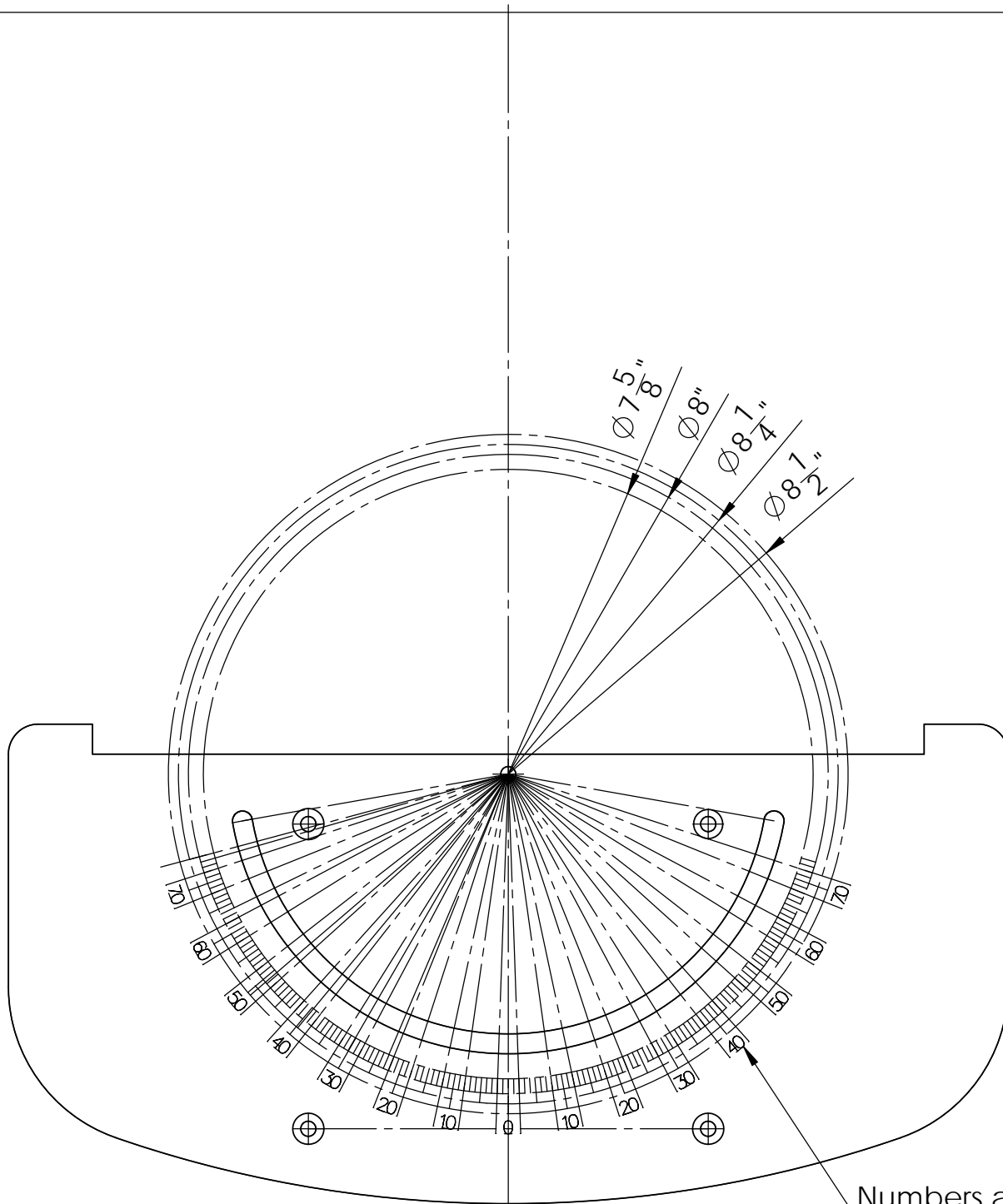

Numbers are 16 point

NOTE: Engrave about 0.005" deep

PROPRIETARY AND CONFIDENTIAL
 THE INFORMATION CONTAINED IN THIS DRAWING IS THE SOLE PROPERTY OF MARTIN KENNEDY. ANY REPRODUCTION, FOR OTHER THAN PERSONAL USE, IN PART OR AS A WHOLE WITHOUT EXPRESS PERMISSION IS PROHIBITED.

SIZE A	FILE NAME Tool Grinder Drawings	REV. A
SCALE 1:2	Table Text	SHEET 6 OF 21

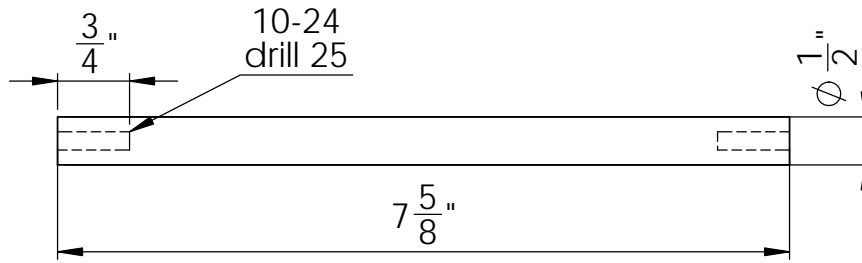

Motor Handle

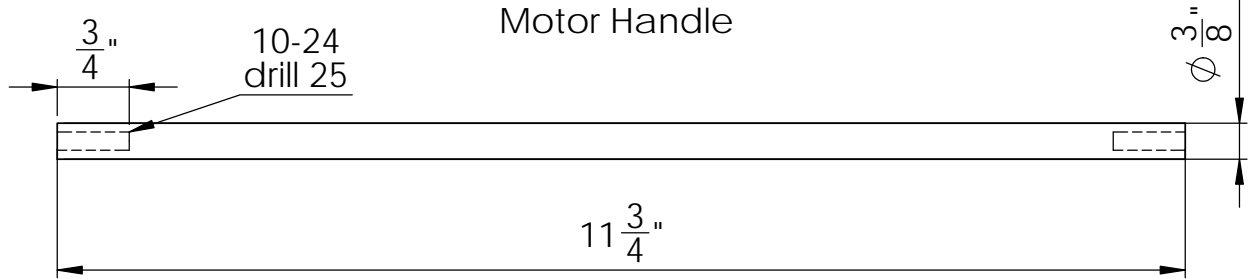

Bottom Bearing Shaft

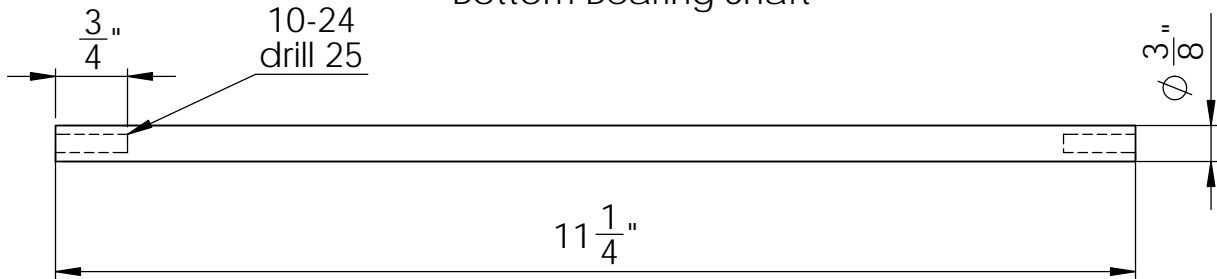

Top Bearing Shaft

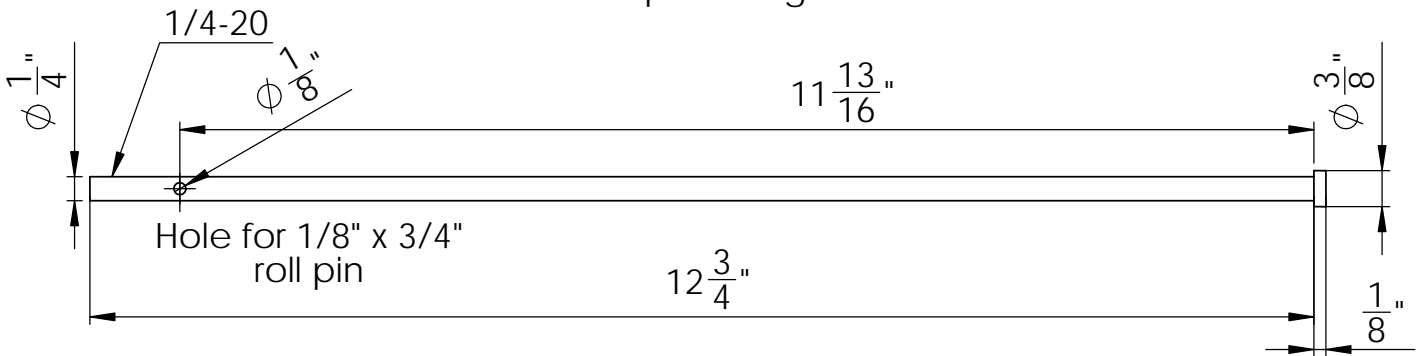

Angle Lock Bolt

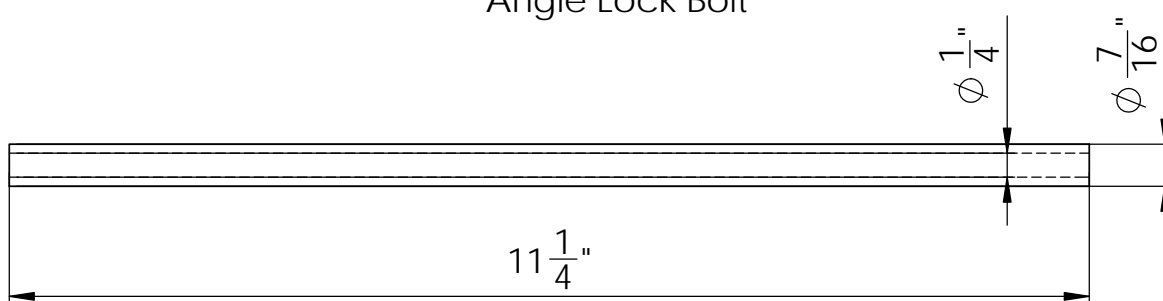

Angle Lock Bolt Spacer Shaft

PROPRIETARY AND CONFIDENTIAL

THE INFORMATION CONTAINED IN THIS DRAWING IS THE SOLE PROPERTY OF MARTIN KENNEDY. ANY REPRODUCTION, FOR OTHER THAN PERSONAL USE, IN PART OR AS A WHOLE WITHOUT EXPRESS PERMISSION IS PROHIBITED.

SIZE FILE NAME
A Tool Grinder Drawings

SCALE 1:2

Rods

REV.
A

SHEET 7 OF 21

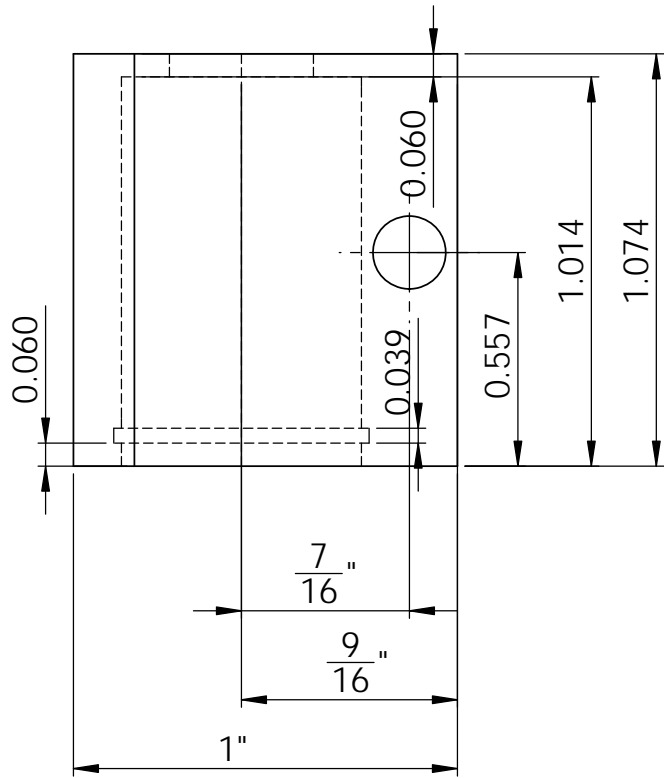

NOTE: Bearing length includes extra space for felt washers to keep grit out of bearing.

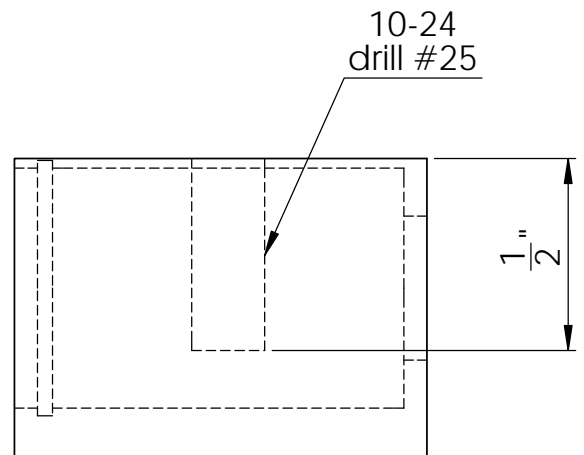
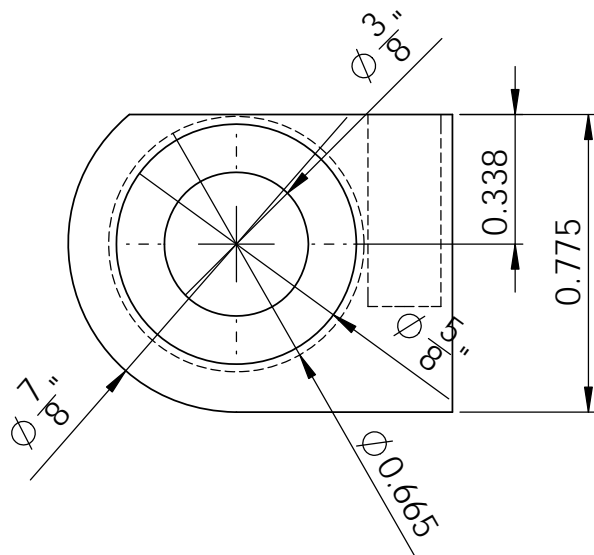
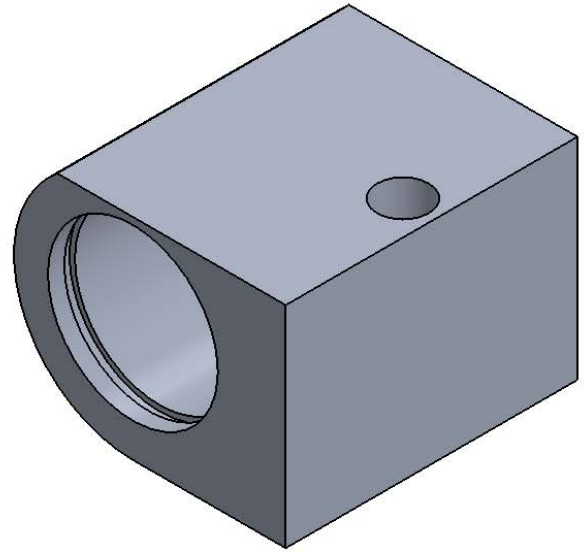

3 required
(including one as mirror image
i.e. circlips face each other)

PROPRIETARY AND CONFIDENTIAL

THE INFORMATION CONTAINED IN THIS DRAWING IS THE SOLE PROPERTY OF MARTIN KENNEDY. ANY REPRODUCTION, FOR OTHER THAN PERSONAL USE, IN PART OR AS A WHOLE WITHOUT EXPRESS PERMISSION IS PROHIBITED.

SIZE FILE NAME
A Tool Grinder Drawings

REV.
A

SCALE 2:1

Bearing Block

SHEET 8 OF 21

NOTE: Keep centerline of polished rod as close to table as possible to minimize offset from grinding wheel when tilting table.

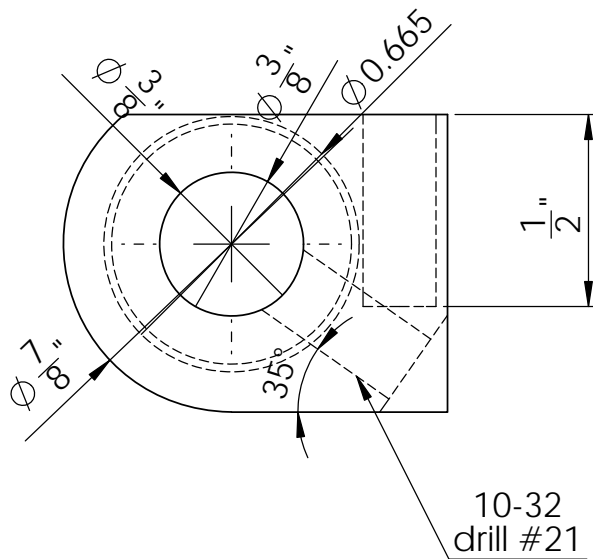
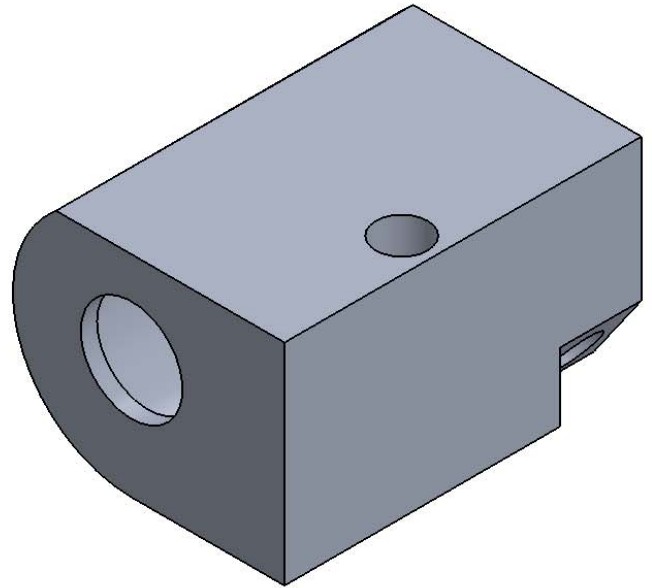
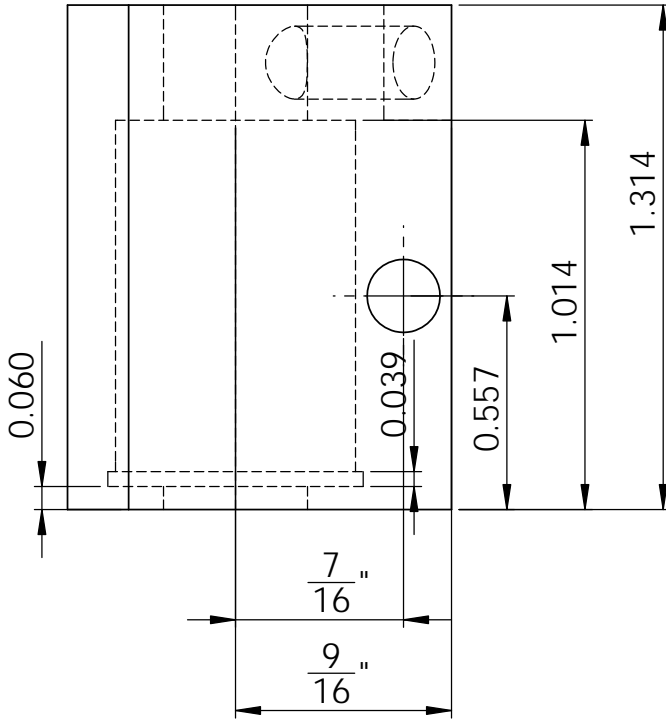

10-24
drill #25

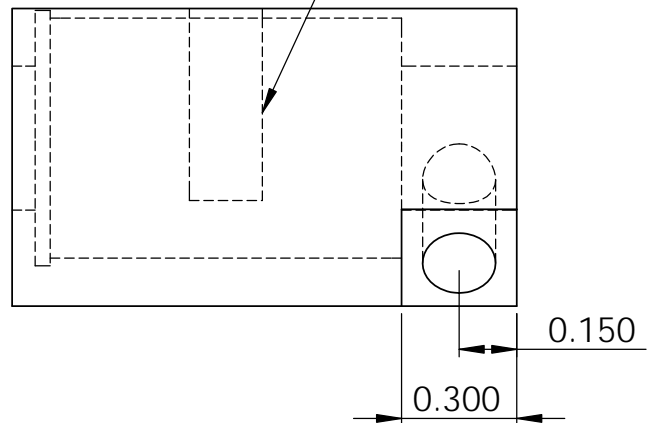

1 required

PROPRIETARY AND CONFIDENTIAL

THE INFORMATION CONTAINED IN THIS DRAWING IS THE SOLE PROPERTY OF MARTIN KENNEDY. ANY REPRODUCTION, FOR OTHER THAN PERSONAL USE, IN PART OR AS A WHOLE WITHOUT EXPRESS PERMISSION IS PROHIBITED.

SIZE FILE NAME
A Tool Grinder Drawings

REV.
A

SCALE 2:1

Bearing Block wLock

SHEET 9 OF 21

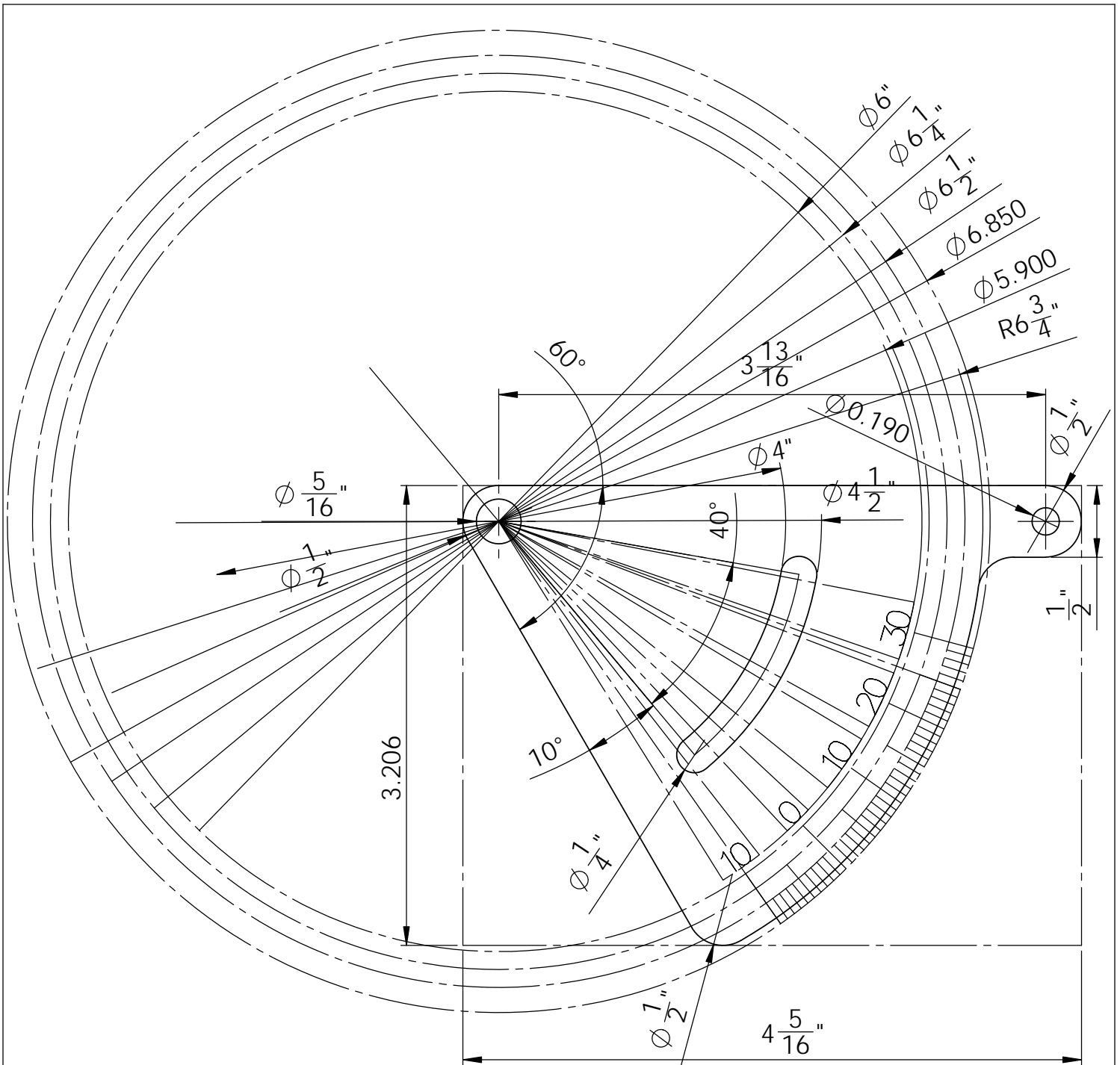

Note: 1/8" thick
 Make two
 Angle scale on one, other blank

PROPRIETARY AND CONFIDENTIAL

THE INFORMATION CONTAINED IN THIS DRAWING IS THE SOLE PROPERTY OF MARTIN KENNEDY. ANY REPRODUCTION, FOR OTHER THAN PERSONAL USE, IN PART OR AS A WHOLE WITHOUT EXPRESS PERMISSION IS PROHIBITED.

SIZE **A** FILE NAME **Tool Grinder Drawings**
 SCALE 1:1 Angle Gauge

REV. **A**

SHEET 10 OF 21

Scribe line

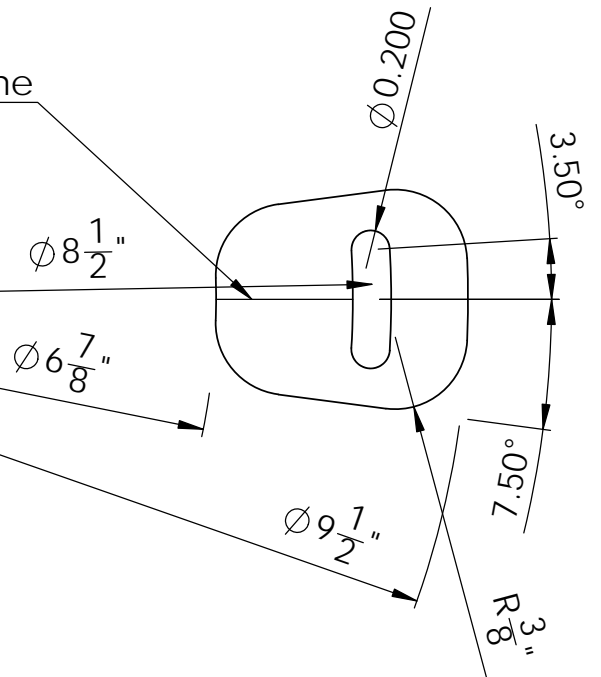

Note: 1/8" thick

PROPRIETARY AND CONFIDENTIAL

THE INFORMATION CONTAINED IN THIS DRAWING IS THE SOLE PROPERTY OF MARTIN KENNEDY. ANY REPRODUCTION, FOR OTHER THAN PERSONAL USE, IN PART OR AS A WHOLE WITHOUT EXPRESS PERMISSION IS PROHIBITED.

SIZE FILE NAME
A Tool Grinder Drawings

REV.
A

SCALE 1:1

Zero Tab

SHEET 11 OF 21

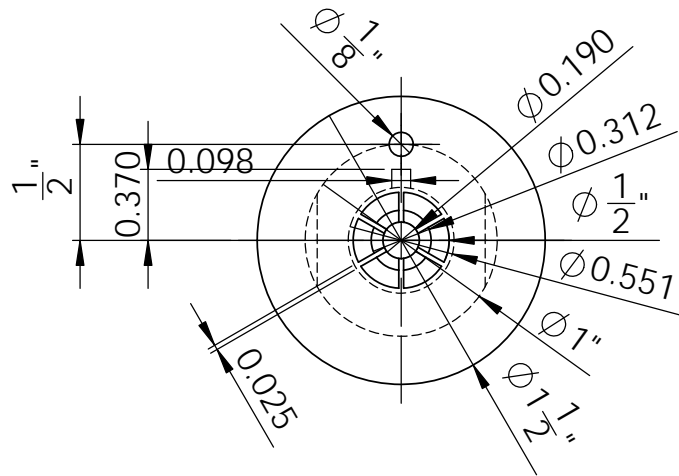
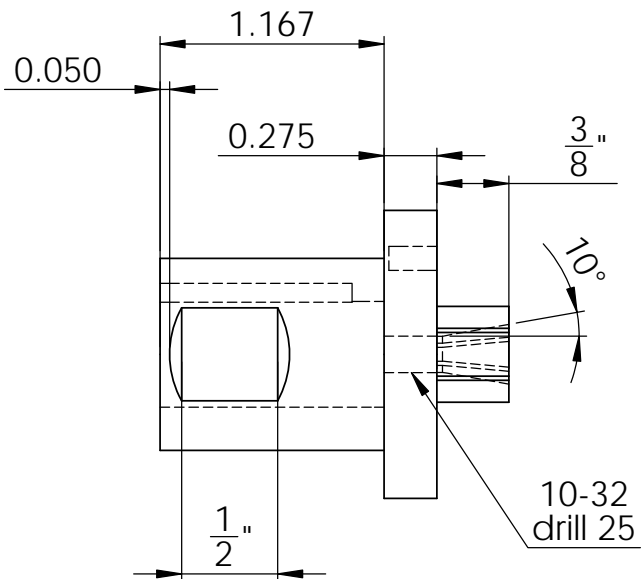

NOTE: Modify to fit your motor
 Cut 10 degree taper on 10 -32
 cap screw to fit hub

PROPRIETARY AND CONFIDENTIAL

THE INFORMATION CONTAINED IN THIS DRAWING IS THE SOLE PROPERTY OF MARTIN KENNEDY. ANY REPRODUCTION, FOR OTHER THAN PERSONAL USE, IN PART OR AS A WHOLE WITHOUT EXPRESS PERMISSION IS PROHIBITED.

SIZE A	FILE NAME Tool Grinder Drawings	REV. A
SCALE 1:1	Mounting Hub	SHEET 12 OF 21

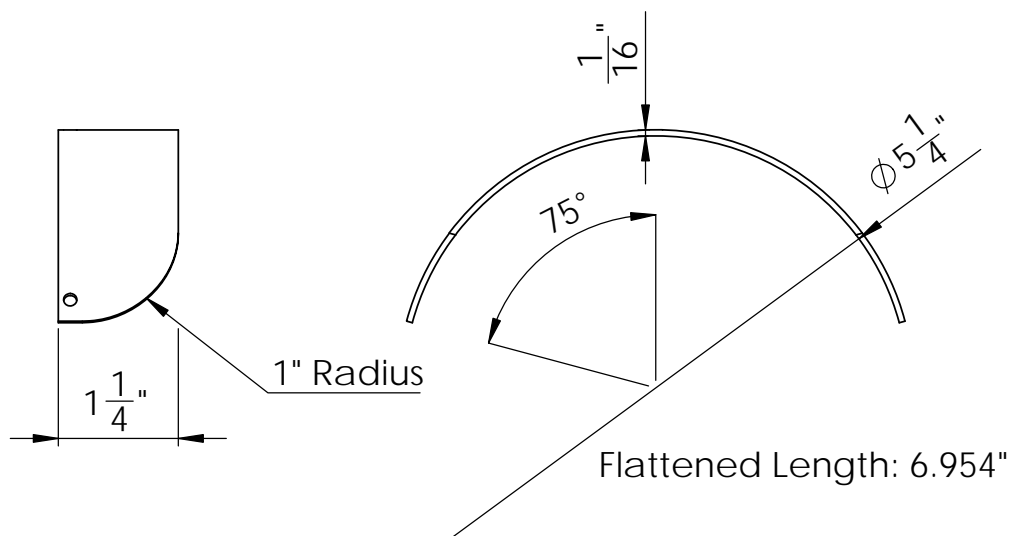
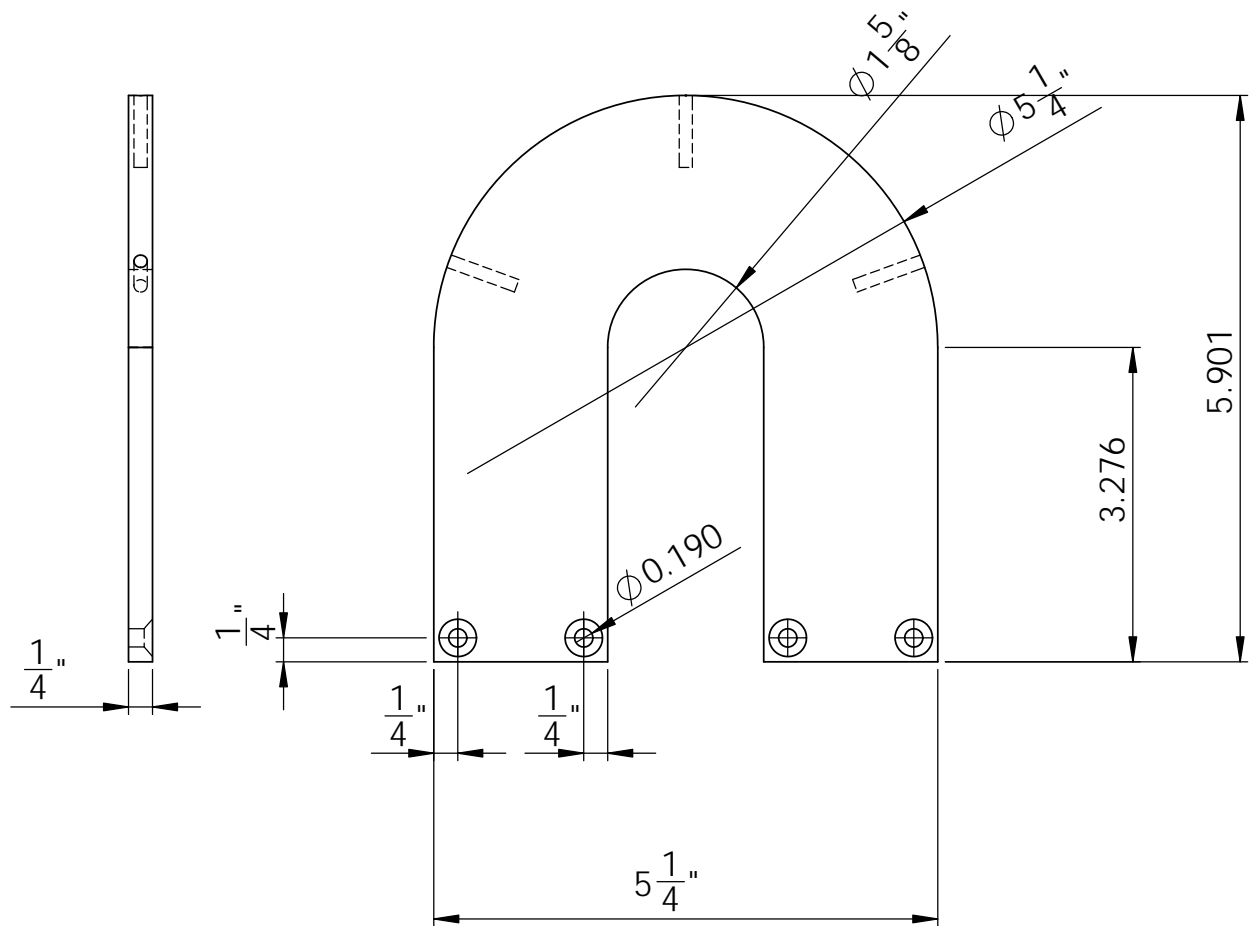

PROPRIETARY AND CONFIDENTIAL

THE INFORMATION CONTAINED IN THIS DRAWING IS THE SOLE PROPERTY OF MARTIN KENNEDY. ANY REPRODUCTION, FOR OTHER THAN PERSONAL USE, IN PART OR AS A WHOLE WITHOUT EXPRESS PERMISSION IS PROHIBITED.

SIZE **A** FILE NAME
Tool Grinder Drawings

REV.
A

SCALE 1:2

Wheel Guard

SHEET 13 OF 21

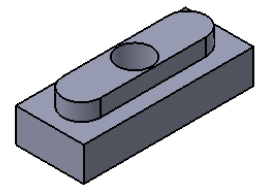
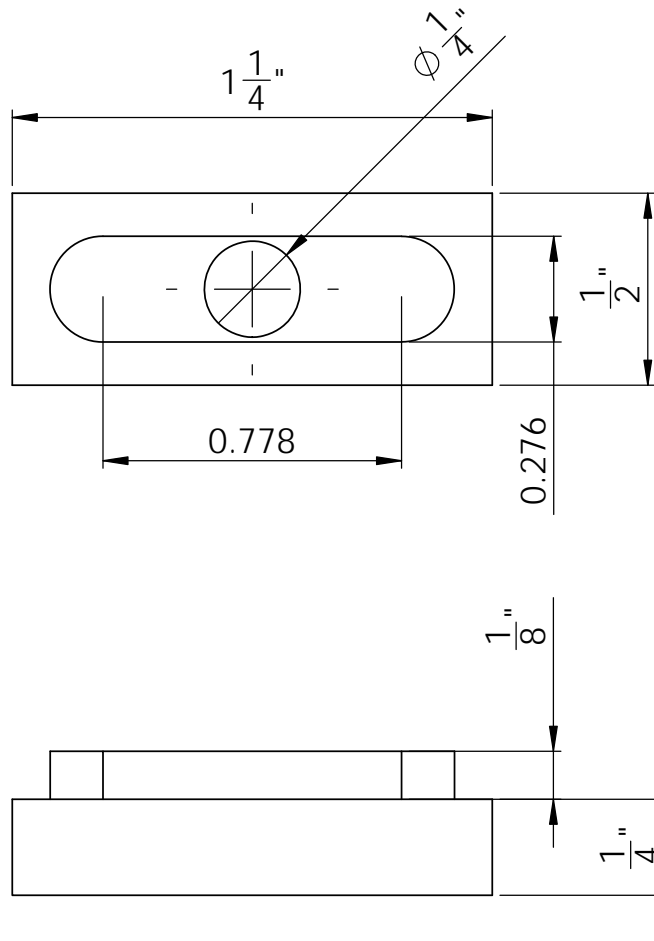

SCALE 1 : 1

PROPRIETARY AND CONFIDENTIAL

THE INFORMATION CONTAINED IN THIS DRAWING IS THE SOLE PROPERTY OF MARTIN KENNEDY. ANY REPRODUCTION, FOR OTHER THAN PERSONAL USE, IN PART OR AS A WHOLE WITHOUT EXPRESS PERMISSION IS PROHIBITED.

SIZE A	FILE NAME Tool Grinder Drawings	REV. A
SCALE 2:1	Motor Nut	SHEET 14 OF 21

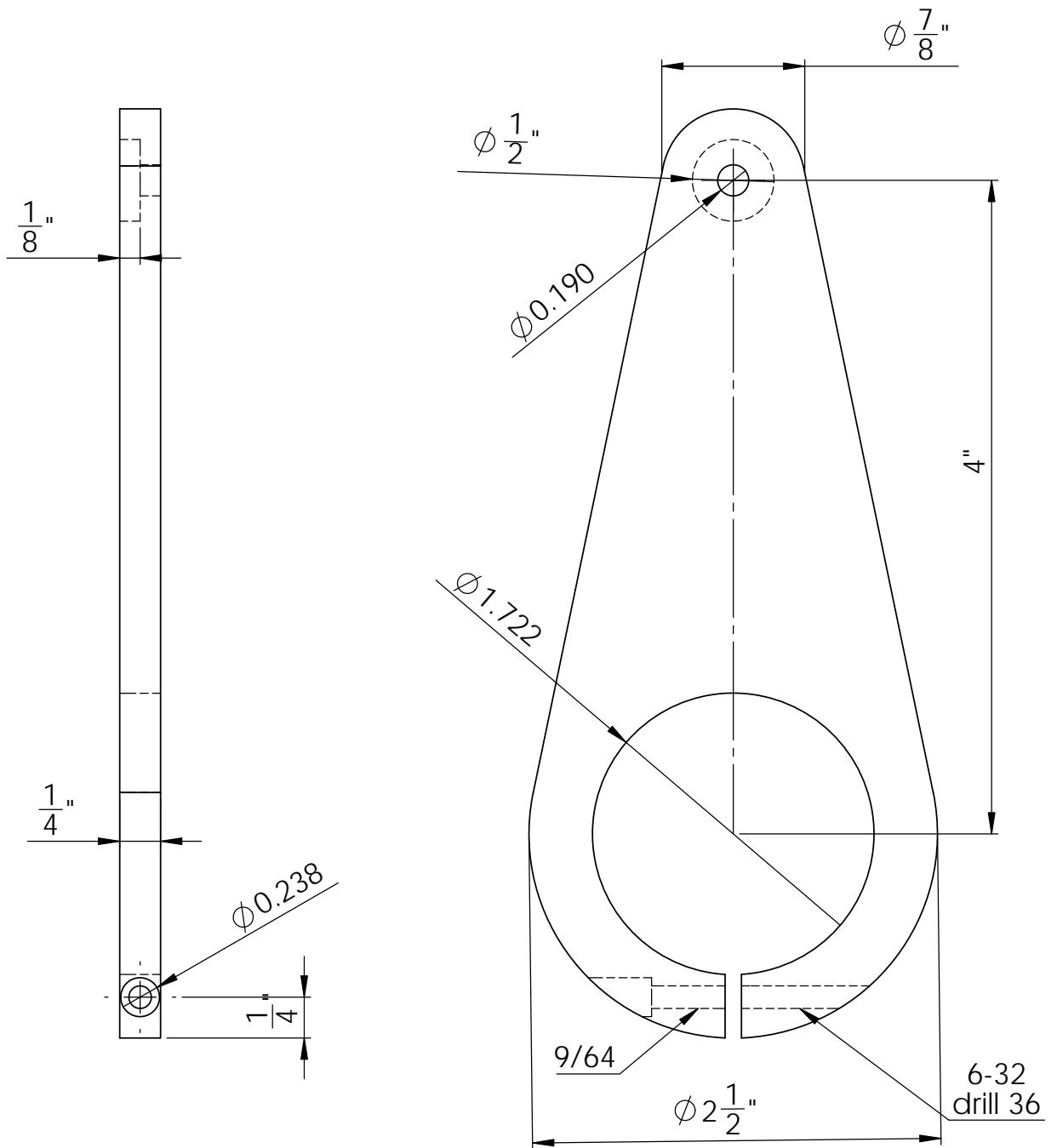

PROPRIETARY AND CONFIDENTIAL

THE INFORMATION CONTAINED IN THIS DRAWING IS THE SOLE PROPERTY OF MARTIN KENNEDY. ANY REPRODUCTION, FOR OTHER THAN PERSONAL USE, IN PART OR AS A WHOLE WITHOUT EXPRESS PERMISSION IS PROHIBITED.

SIZE A	FILE NAME Tool Grinder Drawings	REV. A
SCALE 1:1	Motor Handle Front	SHEET 15 OF 21

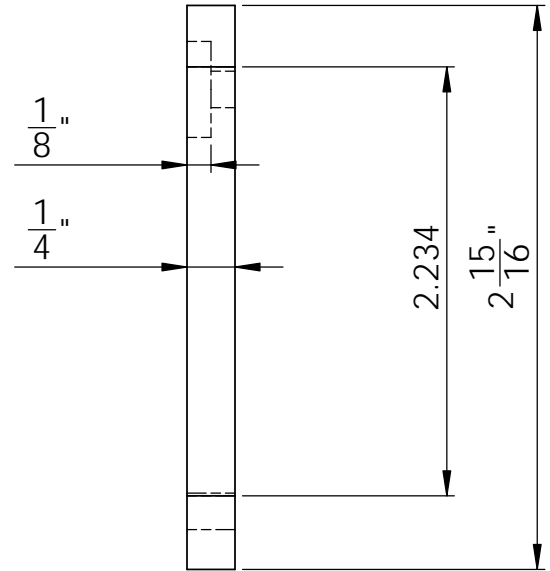
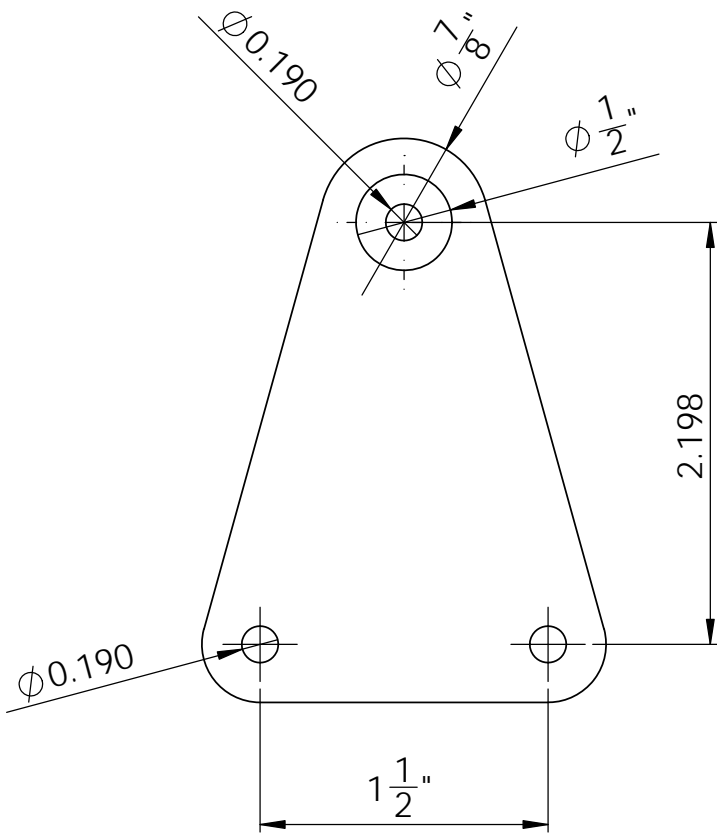

PROPRIETARY AND CONFIDENTIAL

THE INFORMATION CONTAINED IN THIS DRAWING IS THE SOLE PROPERTY OF MARTIN KENNEDY. ANY REPRODUCTION, FOR OTHER THAN PERSONAL USE, IN PART OR AS A WHOLE WITHOUT EXPRESS PERMISSION IS PROHIBITED.

SIZE A	FILE NAME Tool Grinder Drawings	REV. A
SCALE 1:1	Motor Handle Rear	SHEET 16 OF 21

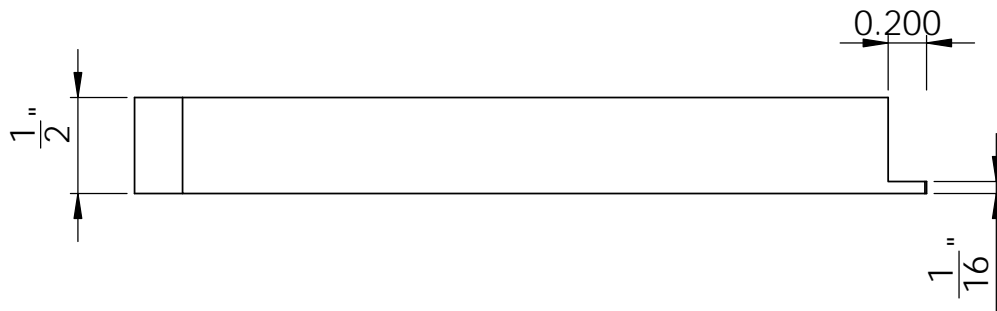
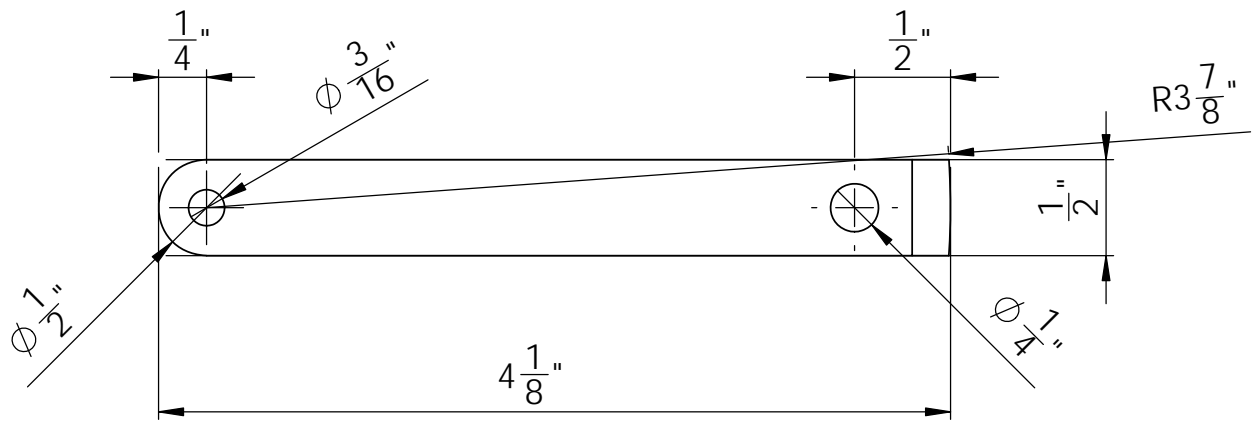

PROPRIETARY AND CONFIDENTIAL

THE INFORMATION CONTAINED IN THIS DRAWING IS THE SOLE PROPERTY OF MARTIN KENNEDY. ANY REPRODUCTION, FOR OTHER THAN PERSONAL USE, IN PART OR AS A WHOLE WITHOUT EXPRESS PERMISSION IS PROHIBITED.

SIZE FILE NAME
A Tool Grinder Drawings

REV.
A

SCALE 1:1

Tool Guide

SHEET 17 OF 21

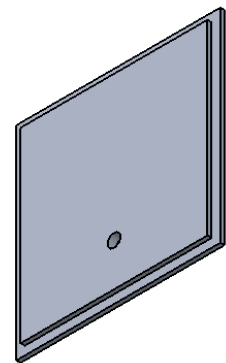
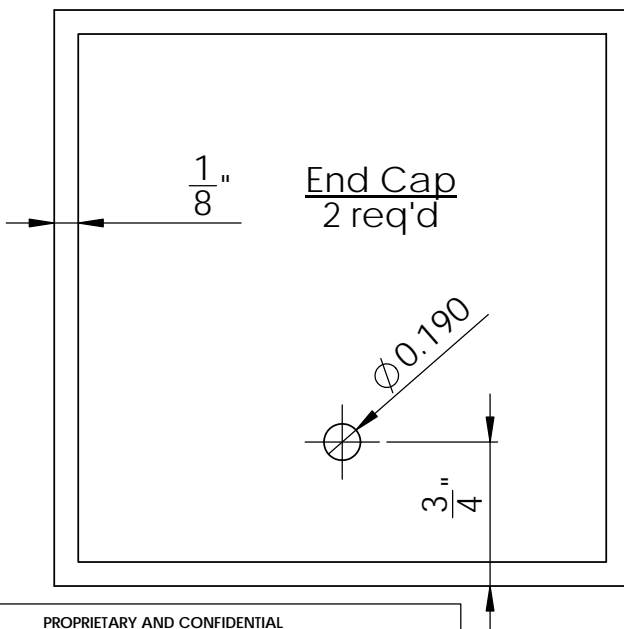
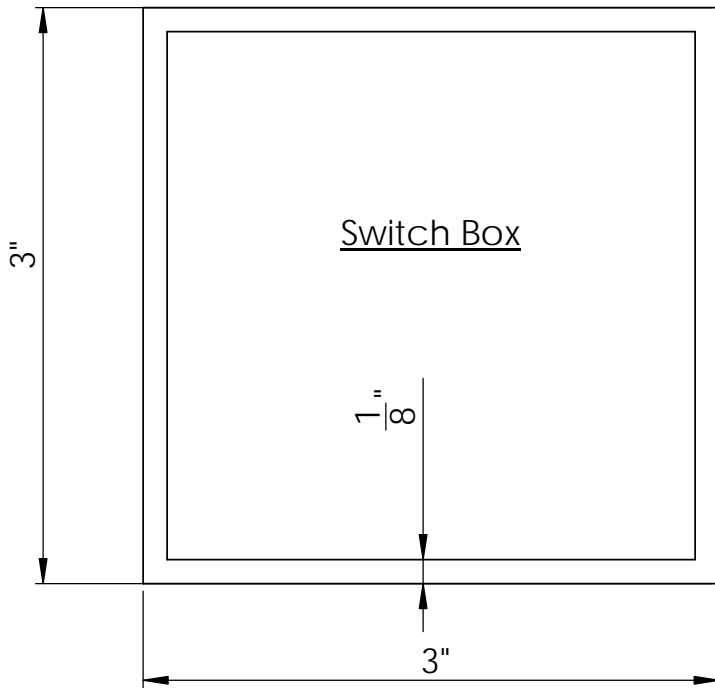
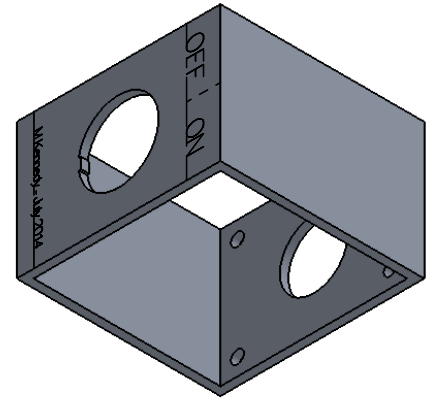
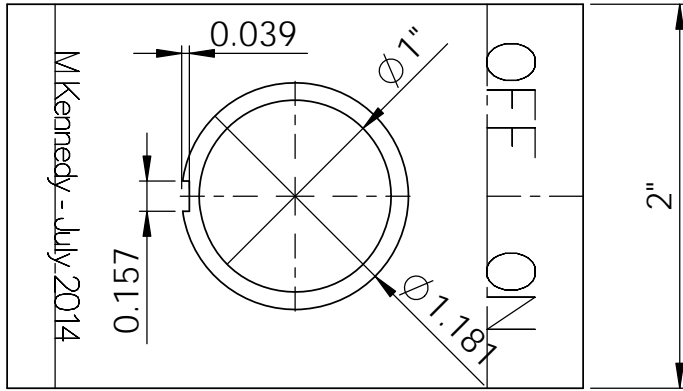

PROPRIETARY AND CONFIDENTIAL

THE INFORMATION CONTAINED IN THIS DRAWING IS THE SOLE PROPERTY OF MARTIN KENNEDY. ANY REPRODUCTION, FOR OTHER THAN PERSONAL USE, IN PART OR AS A WHOLE WITHOUT EXPRESS PERMISSION IS PROHIBITED.

SIZE FILE NAME
A Tool Grinder Drawings

REV.
A

SCALE 1:1

Switch Box

SHEET 18 OF 21

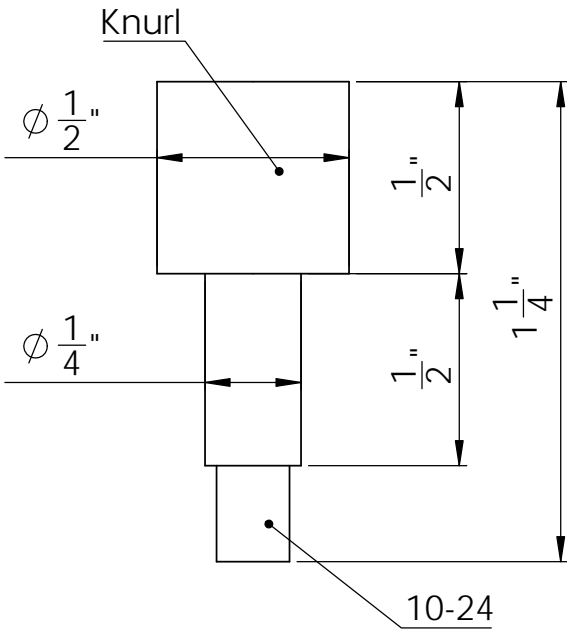

Knurled Screw

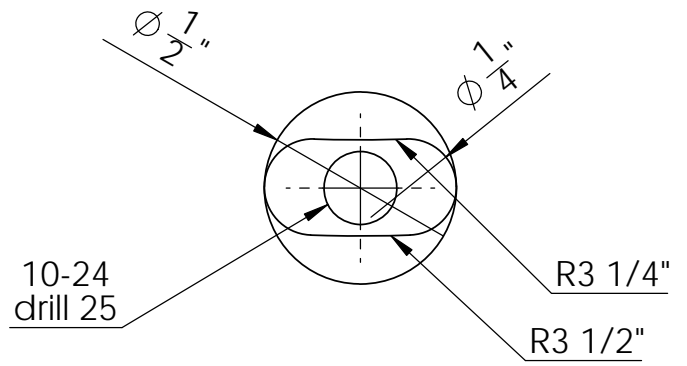

T-Nut

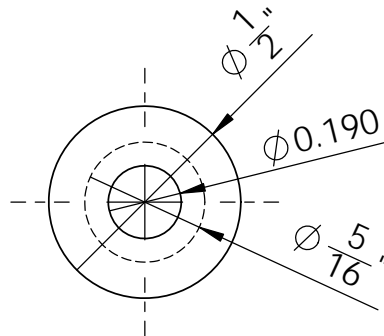
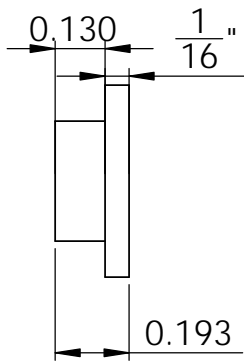

Pivot Bushing
2 req'd

PROPRIETARY AND CONFIDENTIAL

THE INFORMATION CONTAINED IN THIS DRAWING IS THE SOLE PROPERTY OF MARTIN KENNEDY. ANY REPRODUCTION, FOR OTHER THAN PERSONAL USE, IN PART OR AS A WHOLE WITHOUT EXPRESS PERMISSION IS PROHIBITED.

SIZE **A** FILE NAME **Tool Grinder Drawings**

REV. **A**

SCALE 2:1

Misc

SHEET 19 OF 21

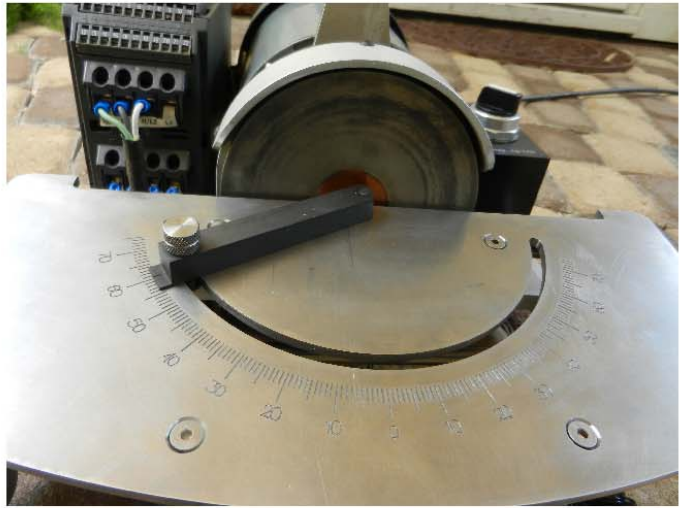

PROPRIETARY AND CONFIDENTIAL

THE INFORMATION CONTAINED IN THIS DRAWING IS THE SOLE PROPERTY OF MARTIN KENNEDY. ANY REPRODUCTION, FOR OTHER THAN PERSONAL USE, IN PART OR AS A WHOLE WITHOUT EXPRESS PERMISSION IS PROHIBITED.

SIZE FILE NAME
A Tool Grinder Drawings

REV.
A

SCALE 1:2

Pictures

SHEET 20 OF 21

NOTES:

Materials of Construction

- Table Stainless Steel or use other material that does not get grit embedded, such as cast iron. Do not use Aluminum!
- Most other material - Aluminum
- Linear bearings and polished rods were on-hand. Can also use parts from discarded printers.
- 1745 RPM 220V 1/2HP 3 phase motor and Siemens Micromaster Vector VFD were on-hand. Can also use reversible 120V motor.
- Abrasive wheel is Glendo / GRS 5", 600 grit medium. Available on eBay.
- Parts designed for CNC mill. Many parts can be simplified for conventional mill.

PROPRIETARY AND CONFIDENTIAL

THE INFORMATION CONTAINED IN THIS DRAWING IS THE SOLE PROPERTY OF MARTIN KENNEDY. ANY REPRODUCTION, FOR OTHER THAN PERSONAL USE, IN PART OR AS A WHOLE WITHOUT EXPRESS PERMISSION IS PROHIBITED.

SIZE A	FILE NAME Tool Grinder Drawings	REV. A
SCALE 1:2	Notes	SHEET 21 OF 21